

GETTING THE RIGHT ROTATION



DEVIANT OLLAM

(HE/THEY OR ANY/ANY)

ASSOCIATED LOCKSMITHS OF AMERICA #102347

INTERNATIONAL ASSOCIATION OF INVESTIGATIVE LOCKSMITHS #2468

SAFE AND VAULT TECHNICIANS OF AMERICA #SR26105

GSA SAFE AND VAULT TECHNICIAN AND INSPECTOR #42992

LIFE SAFETY NFPA & ADA CONSULTANT AND FIRE DOOR INSPECTOR #102347

Hi. I'M DEVIANT. I CRACK SAFES.



Hi. I'M DEVIANT. I CRACK SAFES.

YouTube Premium

Search



How To Break Into a Government Safe



DeviantOllam
150K subscribers

Analytics

Edit video

DOWNLOAD AS: ▼

5.9K



Share

Promote

Download

Clip



94K views 1 year ago

I realized that even though I have talked about safe-cracking on the channel before, I've never showed it to you. Well here you go... this whole process took maybe an hour, from start to finish. That includes all the set up, prep of the container, etc. [...more](#)

488 Comments

Sort by



Add a comment...

All From DeviantOllam Lathes Related



Watchmaking: Machining the Heart of a Watch
Chronova Engineering
448K views · 2 months ago



"Through the Eyes of a Thief" at DakotaCon 2023
DeviantOllam
103K views · 11 months ago

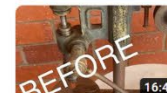

Champion Post Drill , made in England „soulful restoration...
RC Boats Ya Float
99 views · 19 hours ago
New



[1337] My New & Improved Robotic Safe-Cracker...
LockPickingLawyer
1.1M views · 2 years ago



[1350] Defeating a "Killer Key"
LockPickingLawyer
9.3M views · 2 years ago



Woodturning - Hypnotic Blank - I Didn't Think It Would Turn Out...
Jack Mack Woodturning
731K views · 6 months ago



[1455] We Used This To Break Into Our Landlord's Office...
LockPickingLawyer
1.2M views · 1 year ago



We Built A Laser Out Of Tin Foil And Highlighters
The Thought Emporium
1M views · 9 months ago



This Time Last Year... I Was Blind
DeviantOllam
39K views · 2 months ago



How to Bypass RFID Badge Readers (w/ Deviant Ollam an...
The Modern Rogue
1.1M views · 4 years ago

I ALSO ENJOY FOOD AND DRINK



I ALSO ENJOY FOOD AND DRINK



I ALSO ENJOY FOOD AND DRINK

☰ Premium

Search



The Hotel Room Gourmet



DeviantOllam
150K subscribers

Analytics

Edit video

DOWNLOAD AS: ▼

👍 504



➦ Share

🚀 Promote

⬇️ Download

✂️ Clip



22K views 6 years ago

(sorry for the strange aspect ratio on the live footage of the stage... i wasn't responsible for filming! just happy to share!)

Those who know Deviant or Pinup are aware that they love fine food and top-shelf drinks. Whether visiting homes of others, or when guests are gracious enough to come to their place, it's a pleas ...more

72 Comments Sort by



Add a comment...

All From the series From DeviantOllam F >



Howard Payne & Deviant Ollam - This Key is Your Key, This Key ...
DeviantOllam
405K views · 7 years ago



What You Do and Don't Need in a Physical Security Consulting...
DeviantOllam
96K views · 1 year ago



Plastic Knives: A TSA Story
DeviantOllam
51K views · 9 months ago



Liverstrong: A Presentation About Hacking Alcohol
DeviantOllam
22K views · 2 years ago



I'll Let Myself In: Tactics of Physical Pen Testers
Wild West Hackin' Fest
2.8M views · 6 years ago



Lawyer. Passport. Locksmith. Gun. (A Talk About Risk &...
DeviantOllam
125K views · 1 year ago



DEF CON 19 - Deviant Ollam - Safe to Armed in Seconds
DEFCONConference
221K views · 10 years ago



Deviant Ollam "Mastering Master Keys" [HOPE Number 9]
DeviantOllam
231K views · 10 years ago



This Time Last Year... I Was Blind
DeviantOllam
39K views · 2 months ago



Deviant Ollam | The Four Types of Locks | SOURCE Conferenc...
Big Brain Security
104K views · 6 years ago

I ALSO ENJOY FOOD AND DRINK

☰ Premium

Search



CAROLINA CON 14

6. AT-HOME MATURING?

Deviant Ollam

Liverstrong - Upping Your Game with the Cause of and Solution To All of Life's Problems

Liverstrong: A Presentation About Hacking Alcohol



DeviantOllam
150K subscribers

Analytics

Edit video

DOWNLOAD AS: ▼

871



Share

Promote

Download

Clip



22K views 2 years ago

I'm celebrating the end of annual 2022's first Dry Week with a recording of a talk I presented a few years ago in North Carolina. It's all about hacking alcohol in a number of crazy ways. 🍹🍷🍺🍻

Maybe you get a few fun ideas out of it! 🍻🍷🍺🍻 ...more

134 Comments

Sort by



Add a comment...

All From DeviantOllam Related



Elevator Obscura: Hacks and Curios in the Lift Industry
DeviantOllam
387K views • 2 years ago



DRINKING a 159 YEAR old WINE - POISON or PERFECTION?!
Konstantin Baum - Master of W...
3.4M views • 1 year ago



Getting an RFID Implant
The Modern Rogue
630K views • 4 years ago



Lawyer. Passport. Locksmith. Gun. (A Talk About Risk &...)
DeviantOllam
125K views • 1 year ago



Howard Payne & Deviant Ollam - This Key is Your Key, This Key ...
DeviantOllam
405K views • 7 years ago



'Through the Eyes of a Thief' at DakotaCon 2023
DeviantOllam
103K views • 11 months ago



There is No Private Email
By Default
202K views • 5 months ago



You're Probably Not Red Teaming... And Usually I'm Not...
DeviantOllam
499K views • 5 years ago



What You Do and Don't Need in a Physical Security Consulting...
DeviantOllam
96K views • 1 year ago



Gun Storage: The Good, The Bad, and The Ugly of Gun Safe...
DeviantOllam
69K views • 2 years ago

I DON'T LIKE TO FOLLOW ARBITRARY RULES



WHY DO WE USE SAFES?

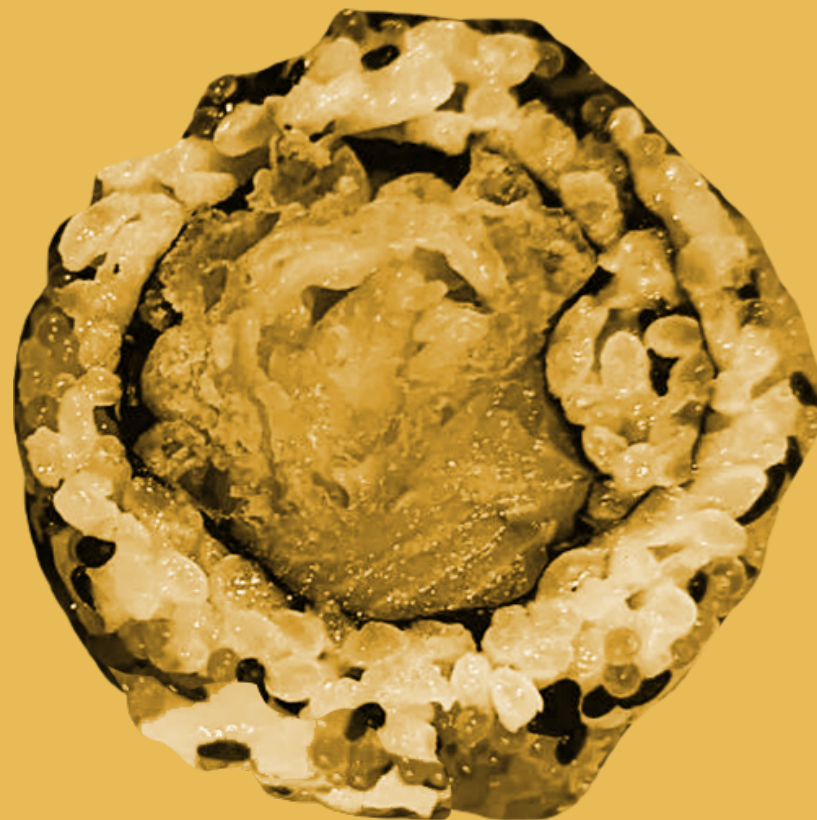

THIS IS A VAULT



VAULT DOOR

WEIGHT: 22 1/2 Tons
THICKNESS: 22 Inches
STEEL: 11 Layers of Special
Cutting and Drill Resistant
LOCKS: 4 Hamilton Watch
Movements for Time Locks

THIS IS A SAFE



THIS IS ALSO (SORT OF) A SAFE

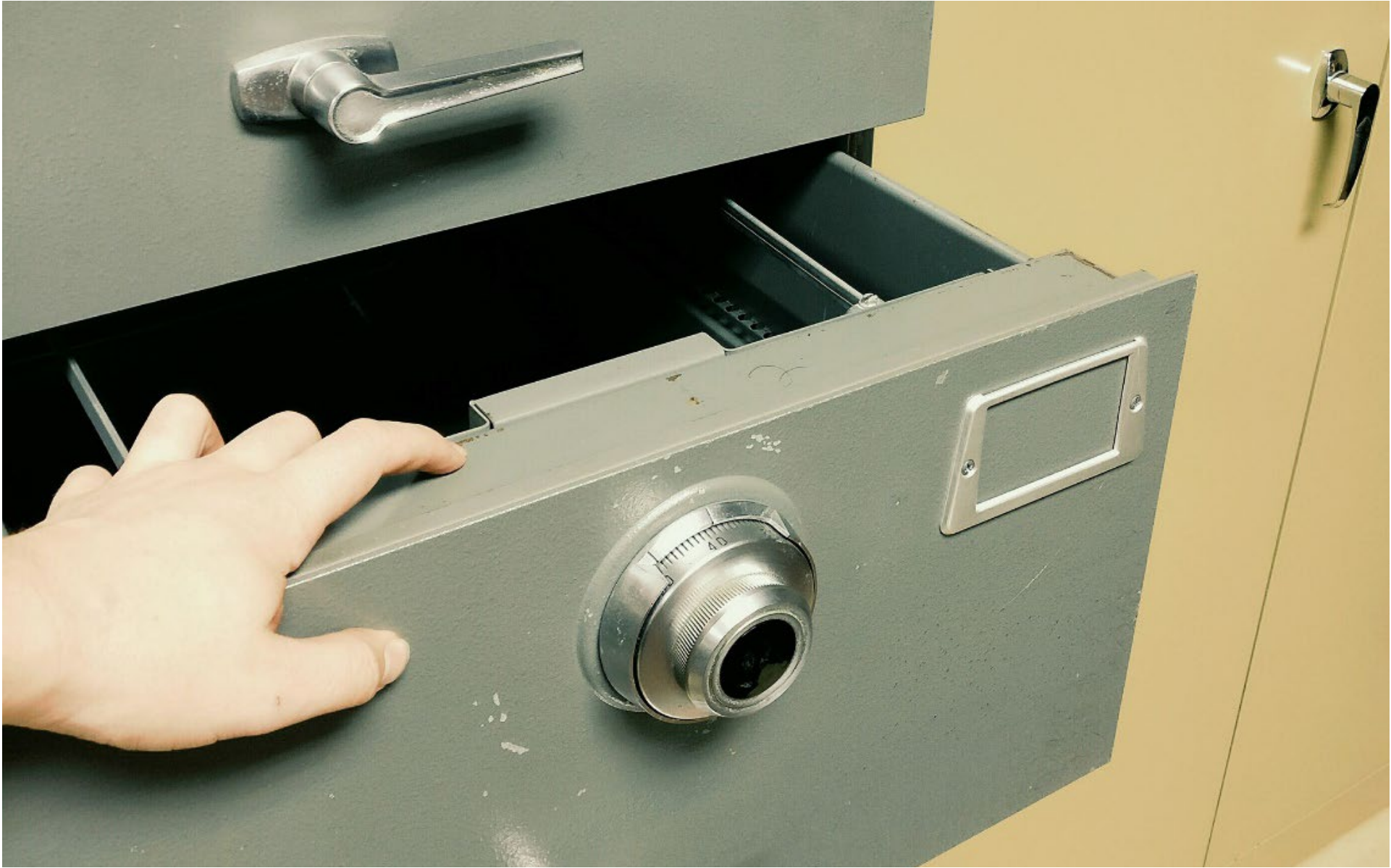

SAFES GUARD AGAINST THIS PERSON



BUT THEY ALSO GUARD AGAINST THIS PERSON



BUT THEY ALSO GUARD AGAINST THIS PERSON



ULTIMATELY, THIS IS WHAT KEEPS THE ASSETS INSIDE SECURE



PEOPLE DENY ATTACKS. SAFES DETER & DELAY ATTACKS.



INTRUSION ISN'T IMPOSSIBLE... BUT IT SHOULD BE SLOW AND OBVIOUS



WHO'S IN YOUR THREAT MODEL?

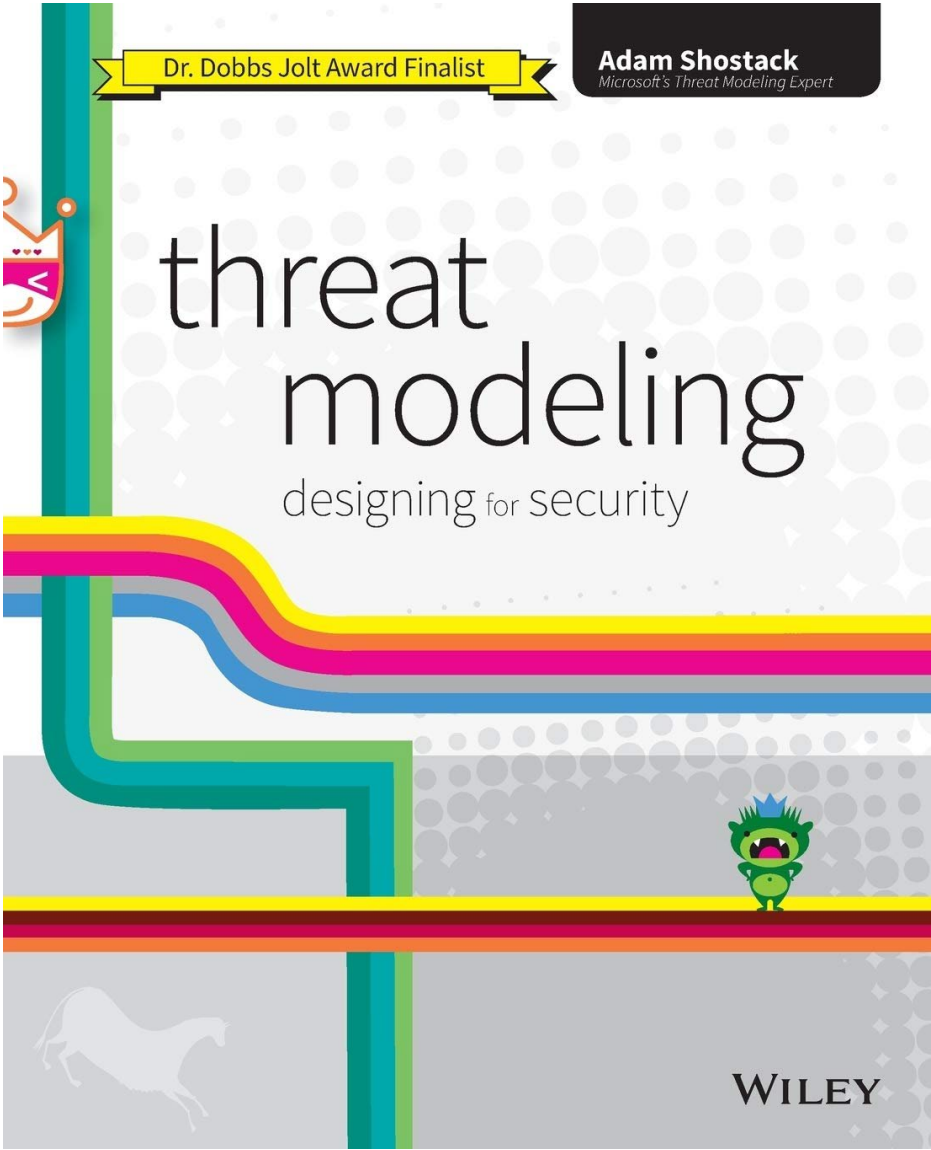

LIMITED SKILL ATTACKERS?



HIGH SKILL ATTACKERS?



PROFESSIONAL SKILL ATTACKERS?



NATION-STATE ATTACKERS?



A WORD ABOUT MECHANICAL SYSTEMS AND BOLTS

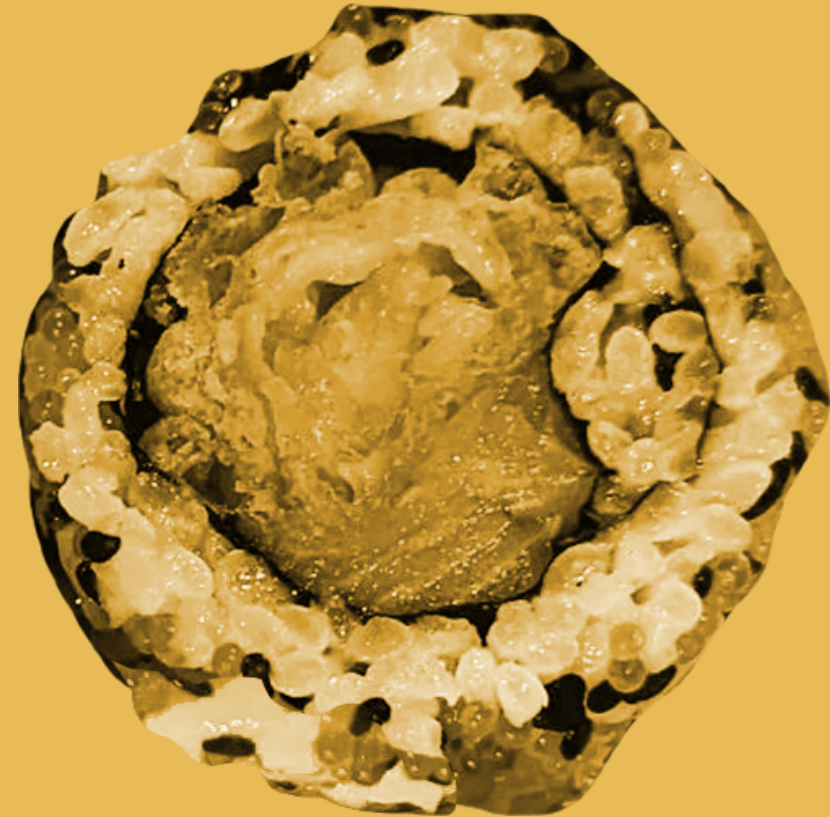

SAFES AND SAFE LOCKS

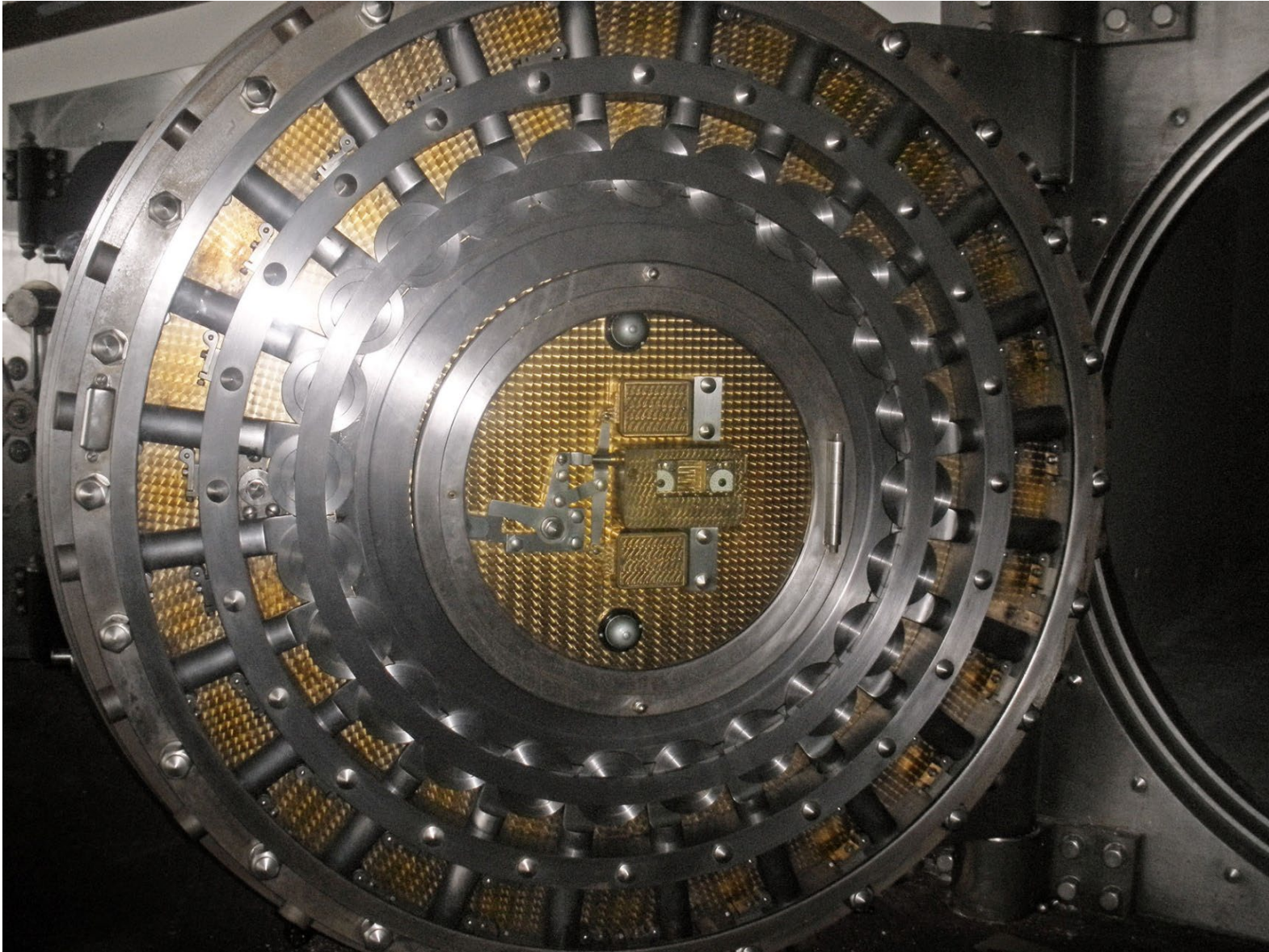

THESE ARE THE LOCKS (DUAL CONTROL VAULT)



INSIDE OF A SAFE LOCK

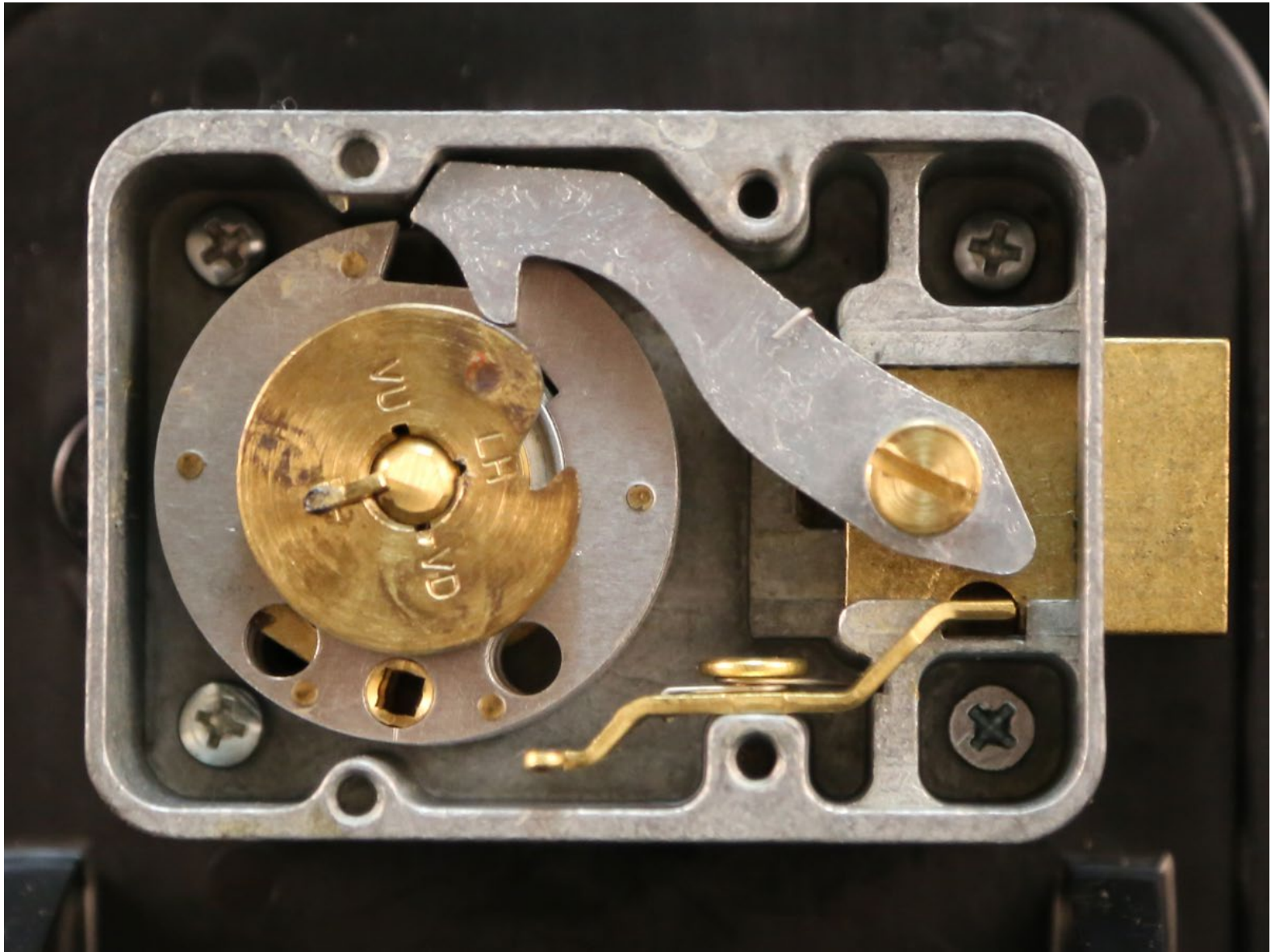

THIS UNIT EVEN FEATURES A TIME LOCK



WHERE ARE THE "BOLTS" ?

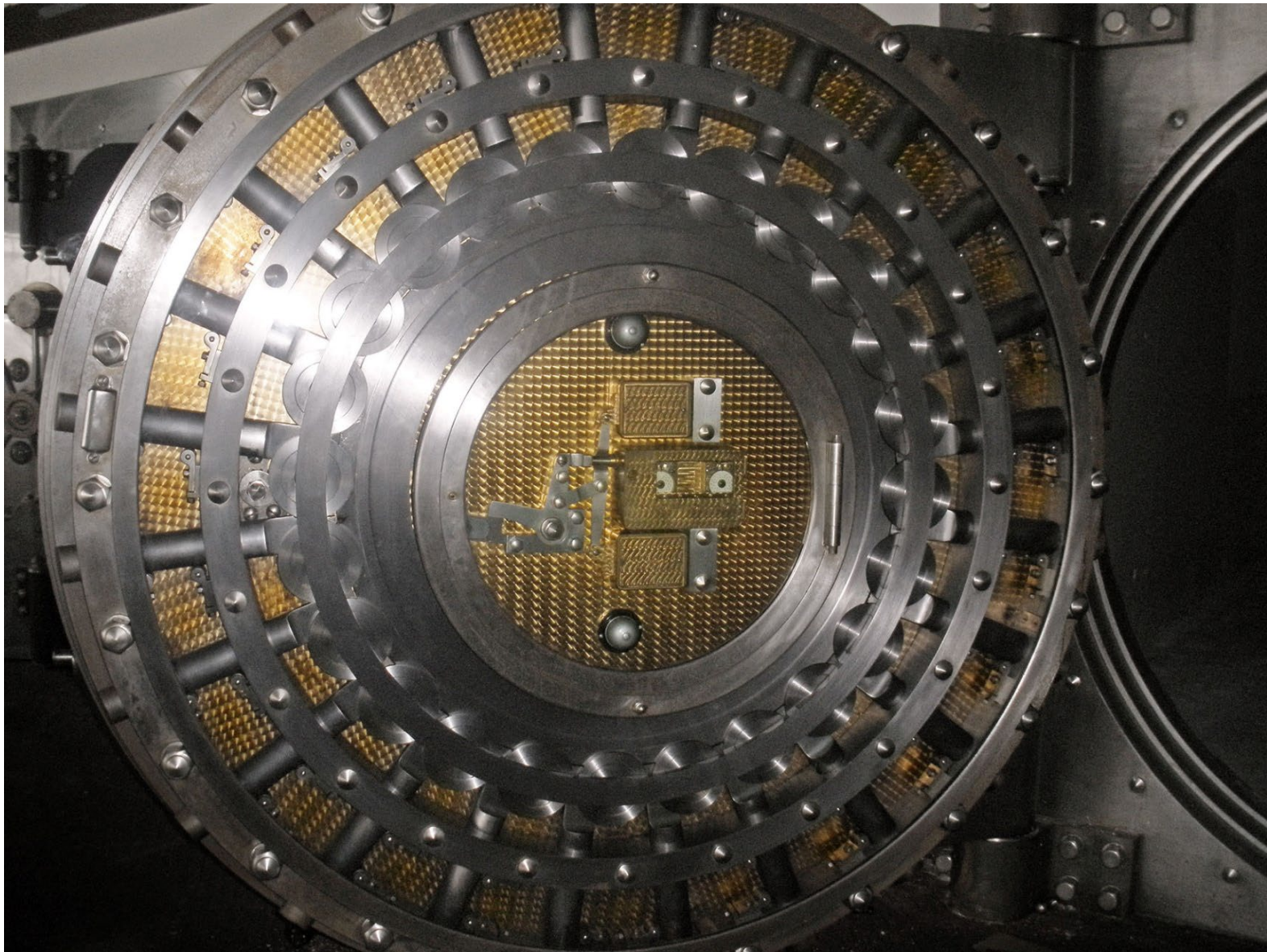

THESE SURE LOOK LIKE THE BOLTS, RIGHT?

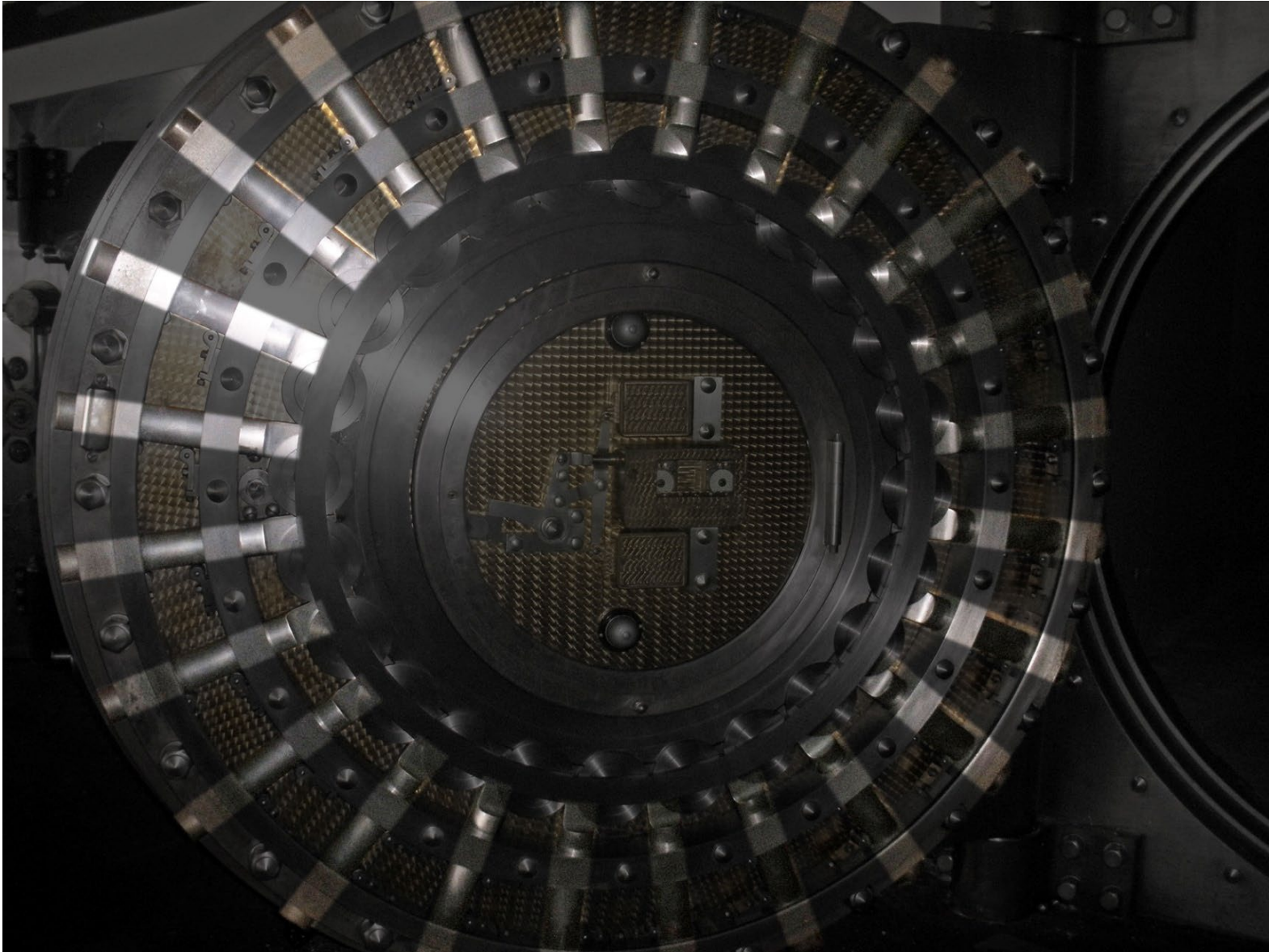

DISTINGUISHING “BOLTWORK” VS “LOCK BOLT”

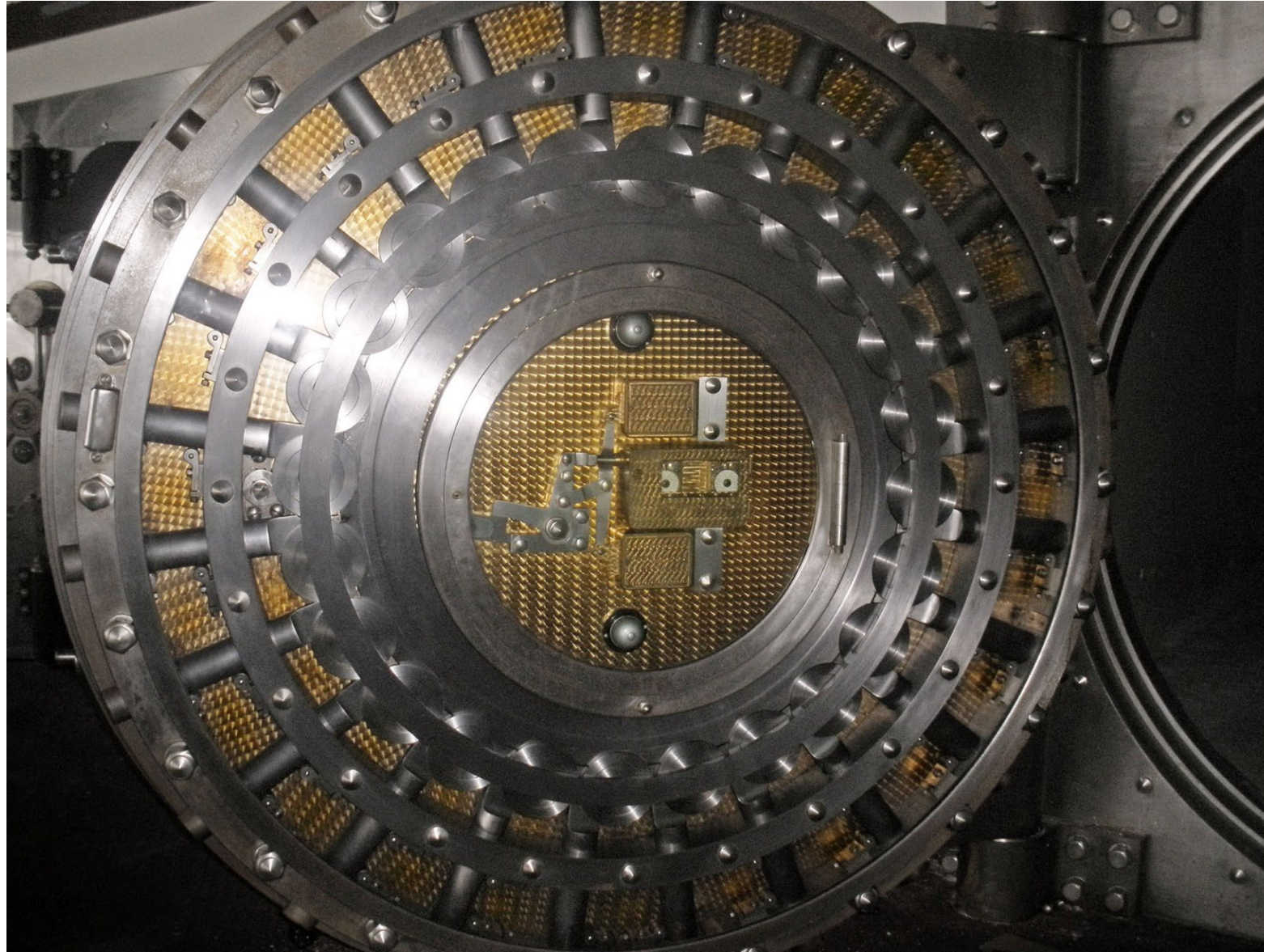

THE SAFE LOCKS EACH HAVE THEIR OWN BOLT

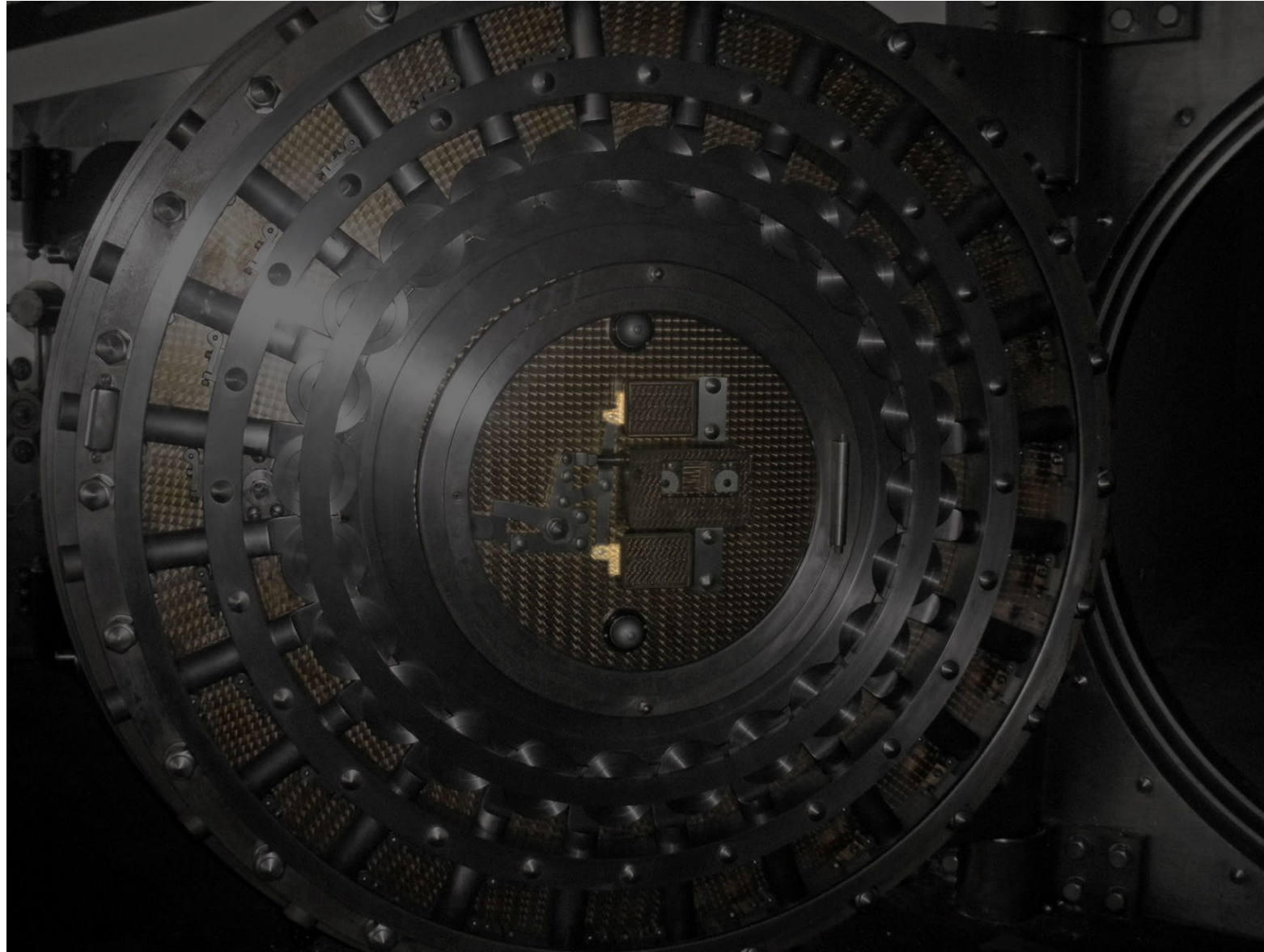

BOLT THROW FUNCTIONALITY

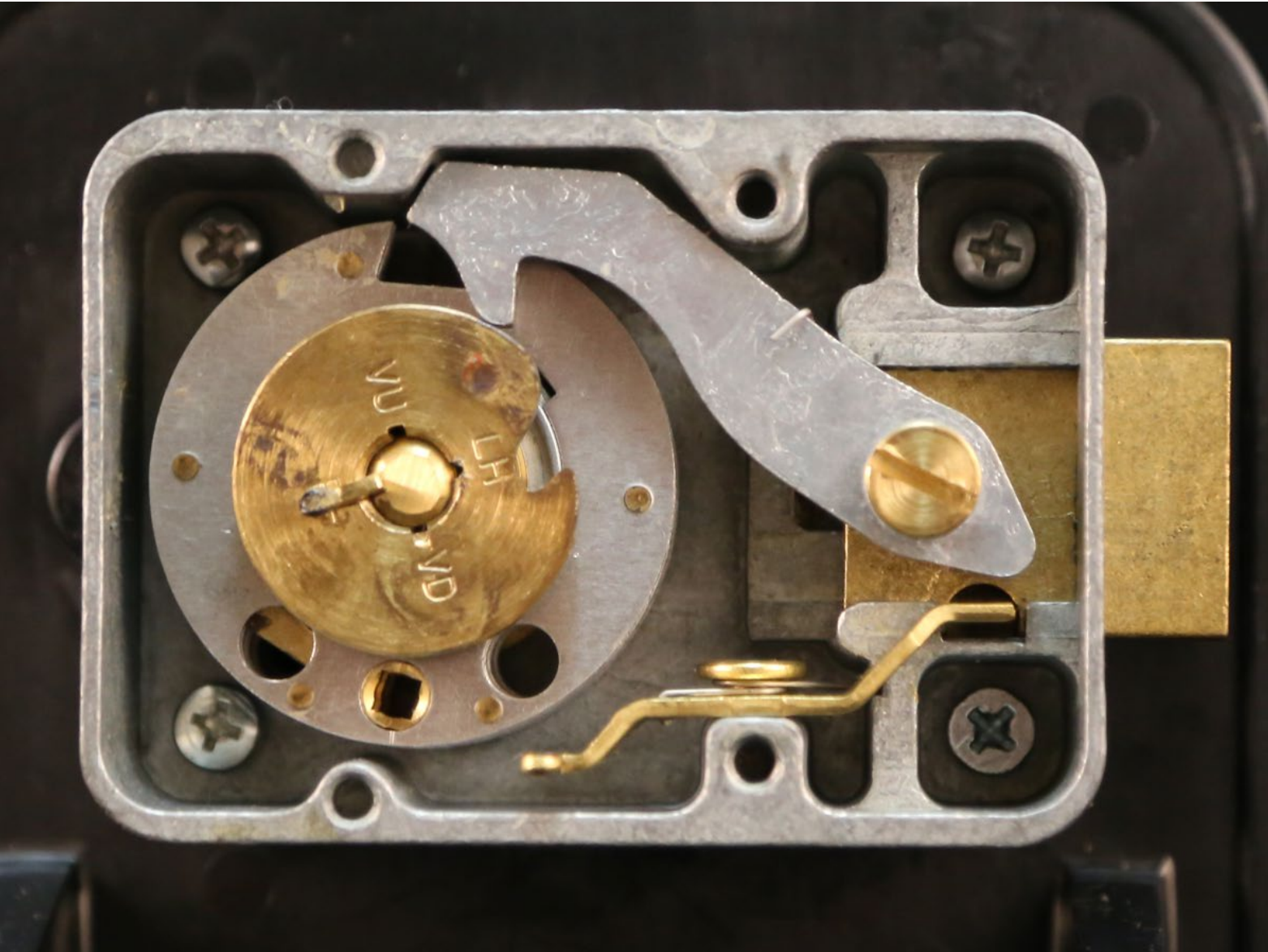

BOLT THROW FUNCTIONALITY

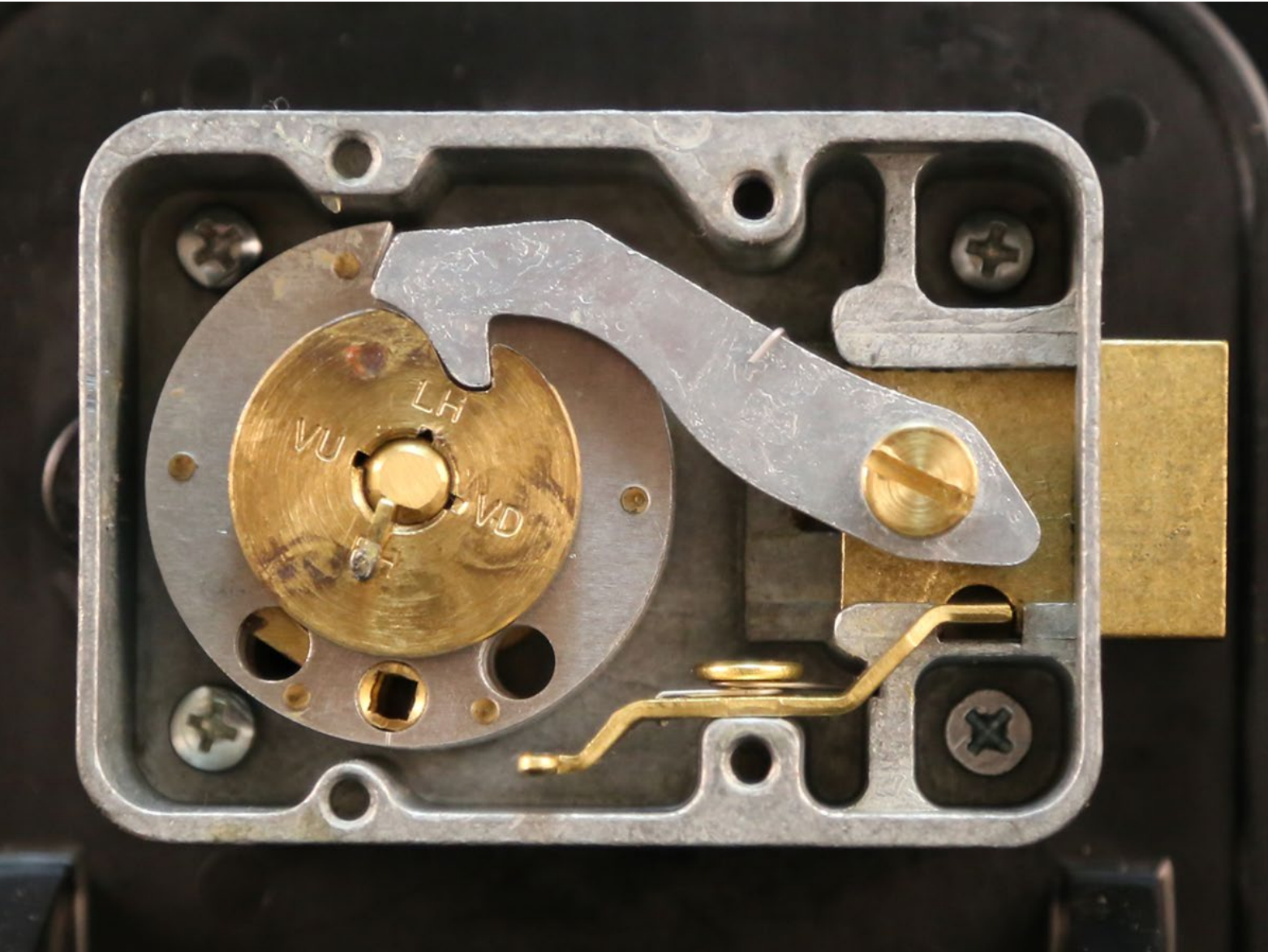

BOLT THROW FUNCTIONALITY

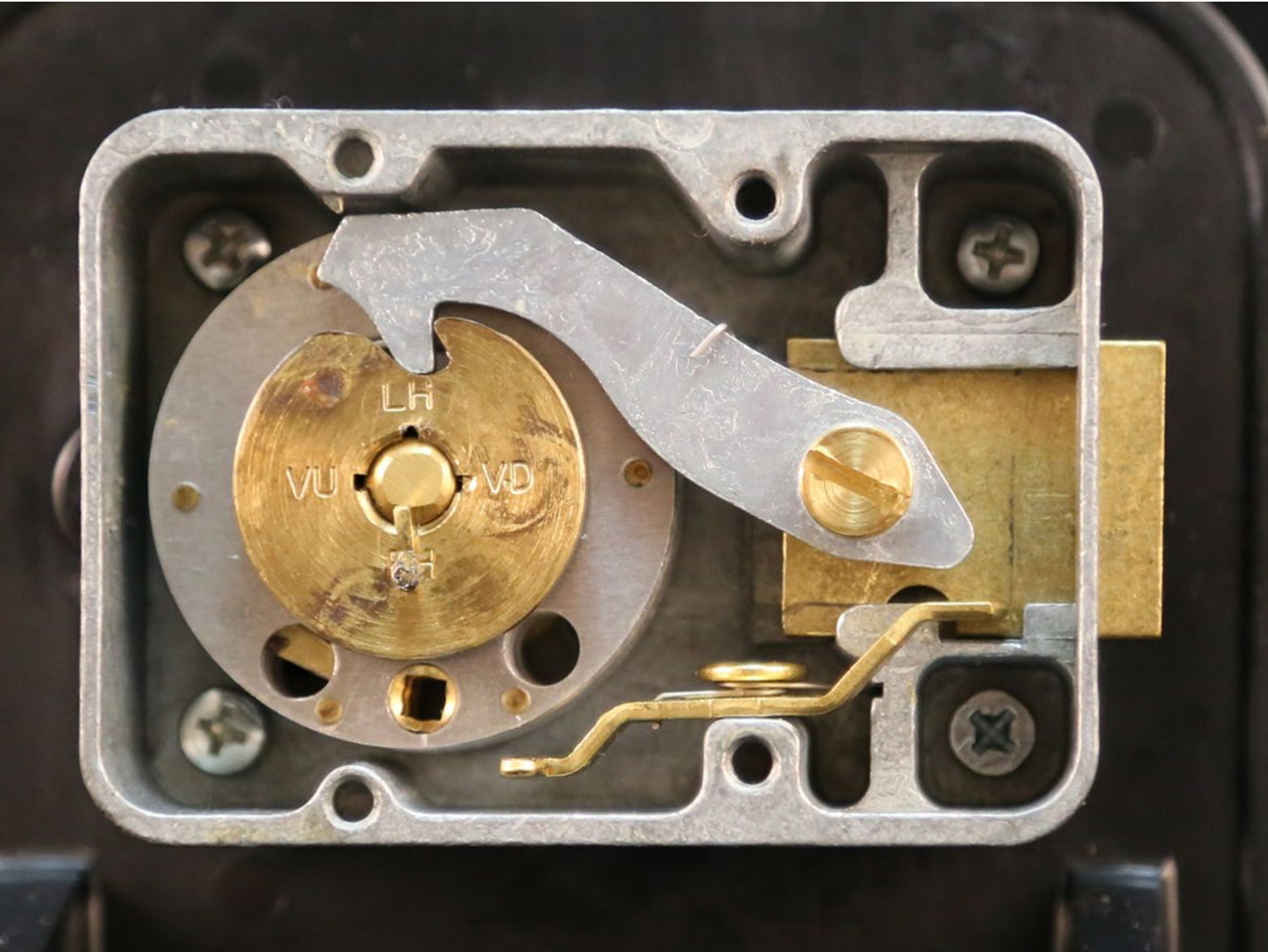

BOLT THROW FUNCTIONALITY

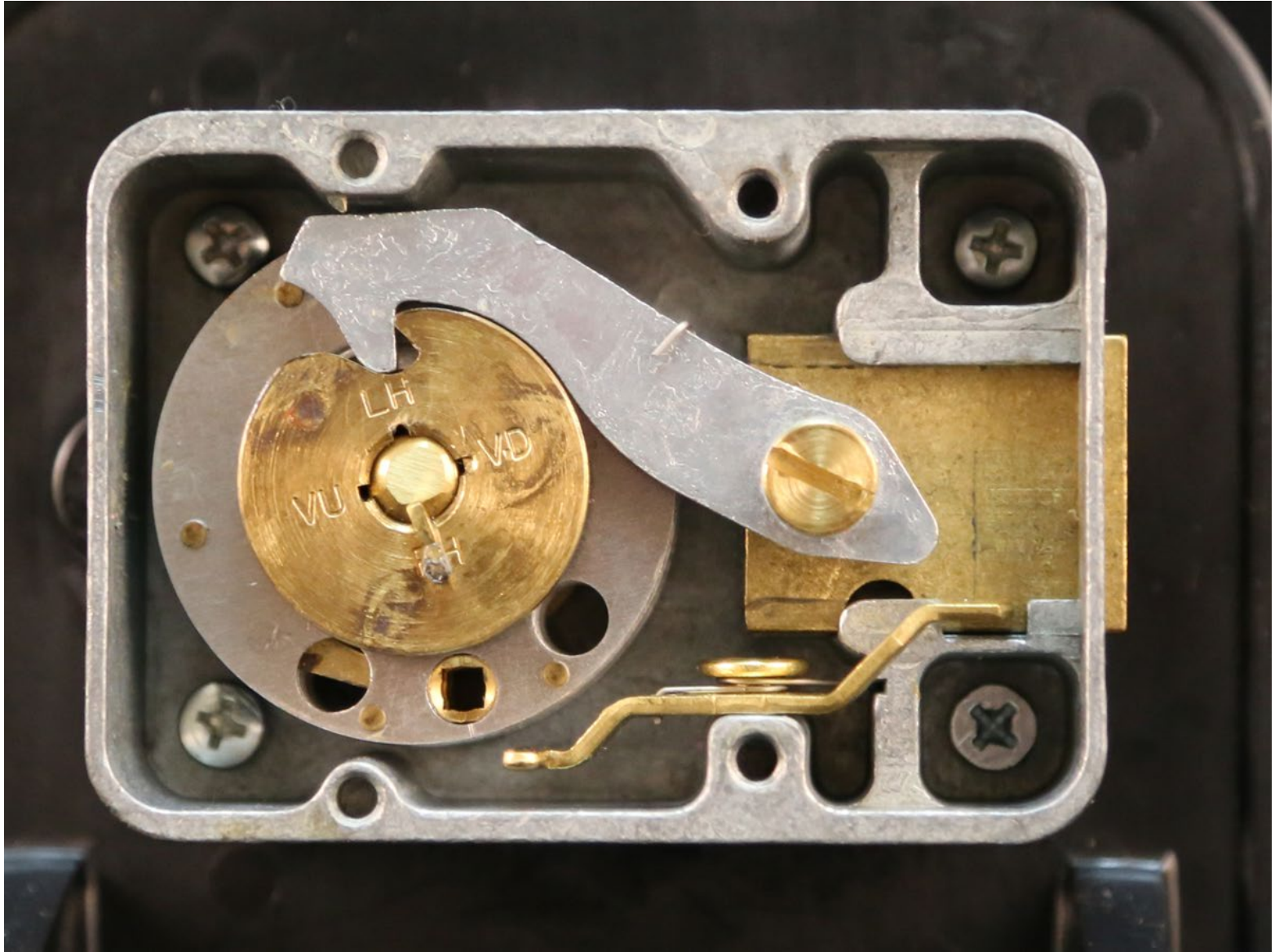

BOLT THROW FUNCTIONALITY

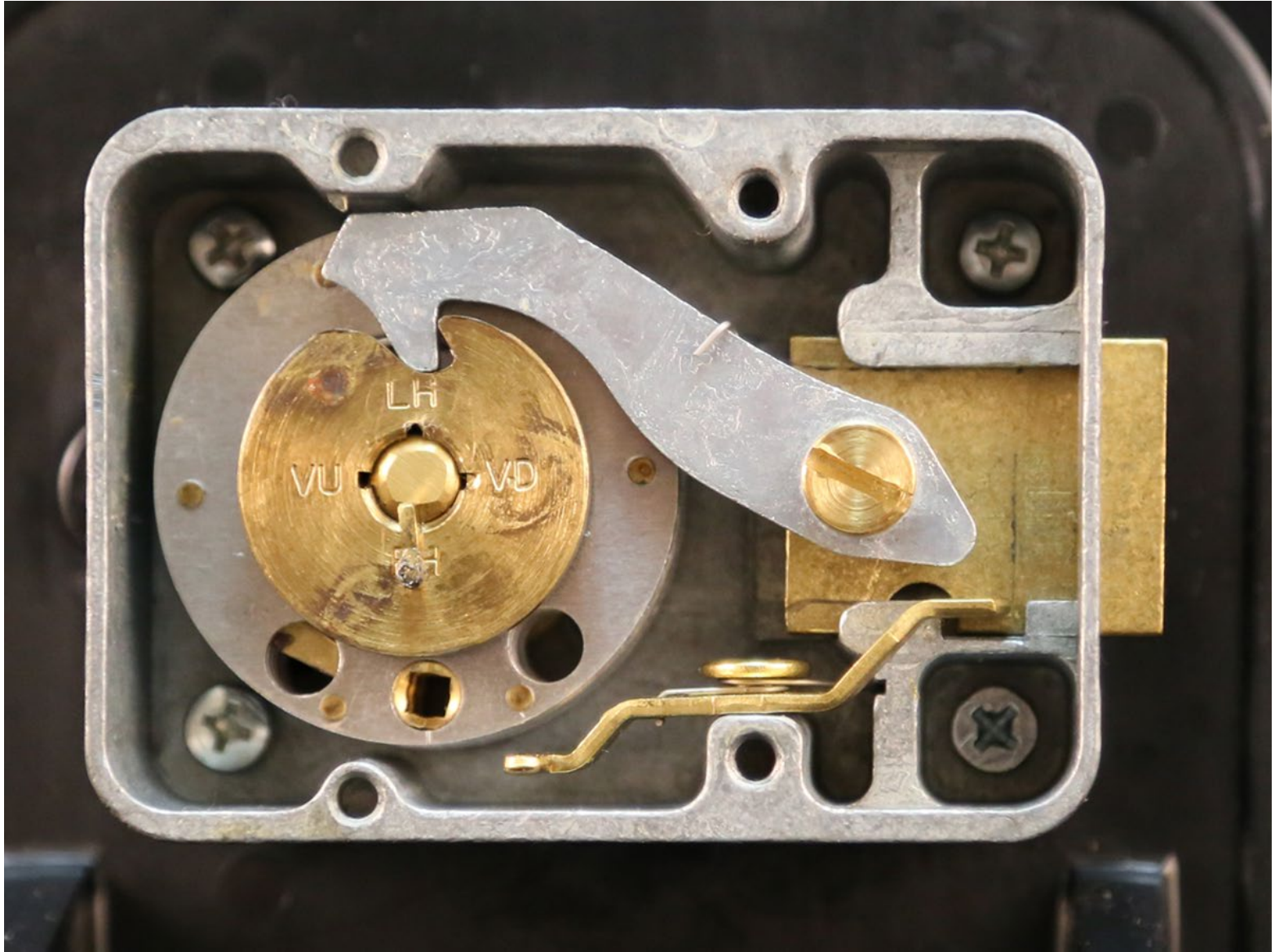

BOLT THROW FUNCTIONALITY

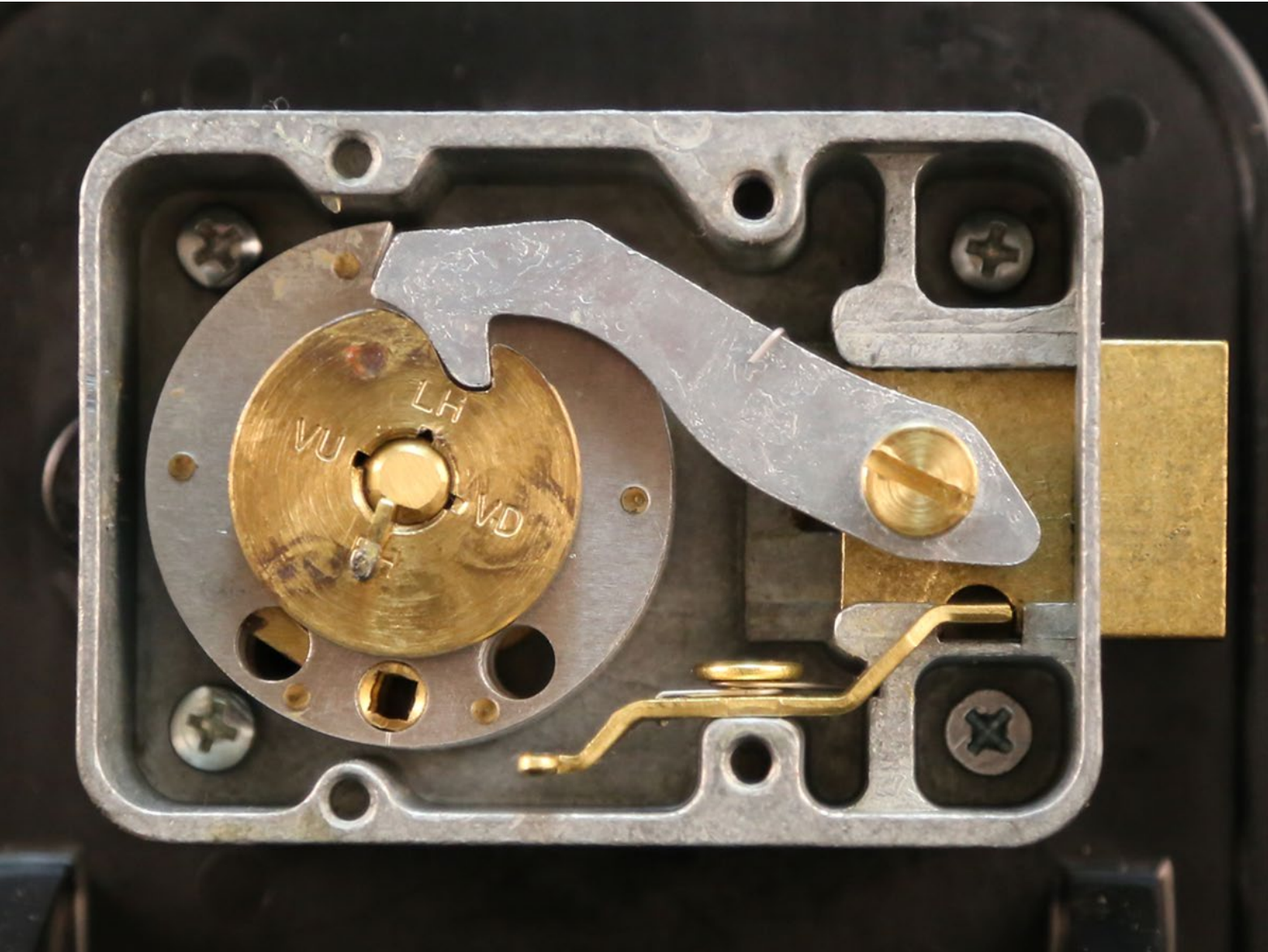

BOLT THROW FUNCTIONALITY



BOLT THROW FUNCTIONALITY



THE LINKAGE OR ARMATURE

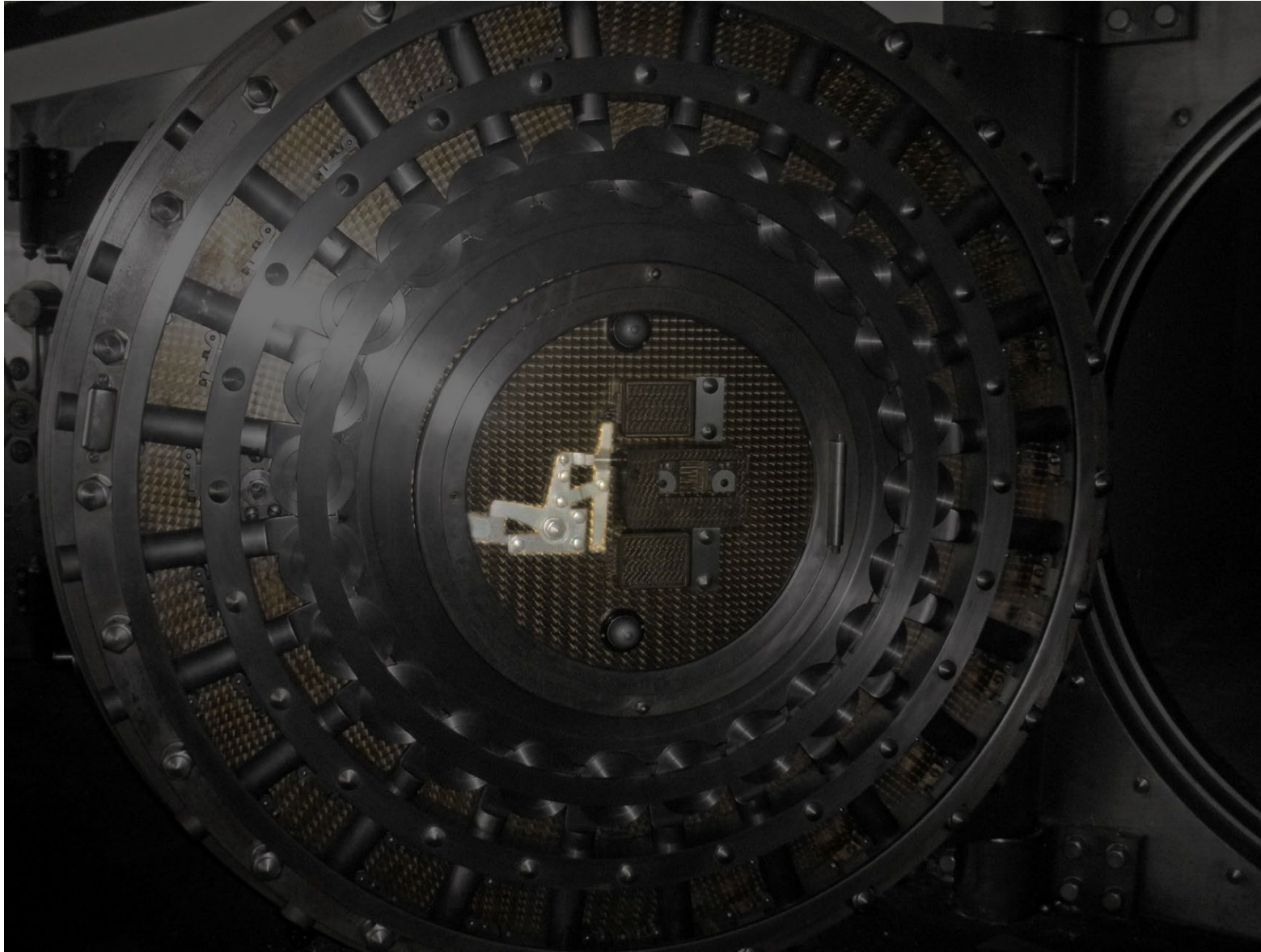

TINY LOCK BOLTS CAN CONTROL MUCH LARGER BOLTWORK

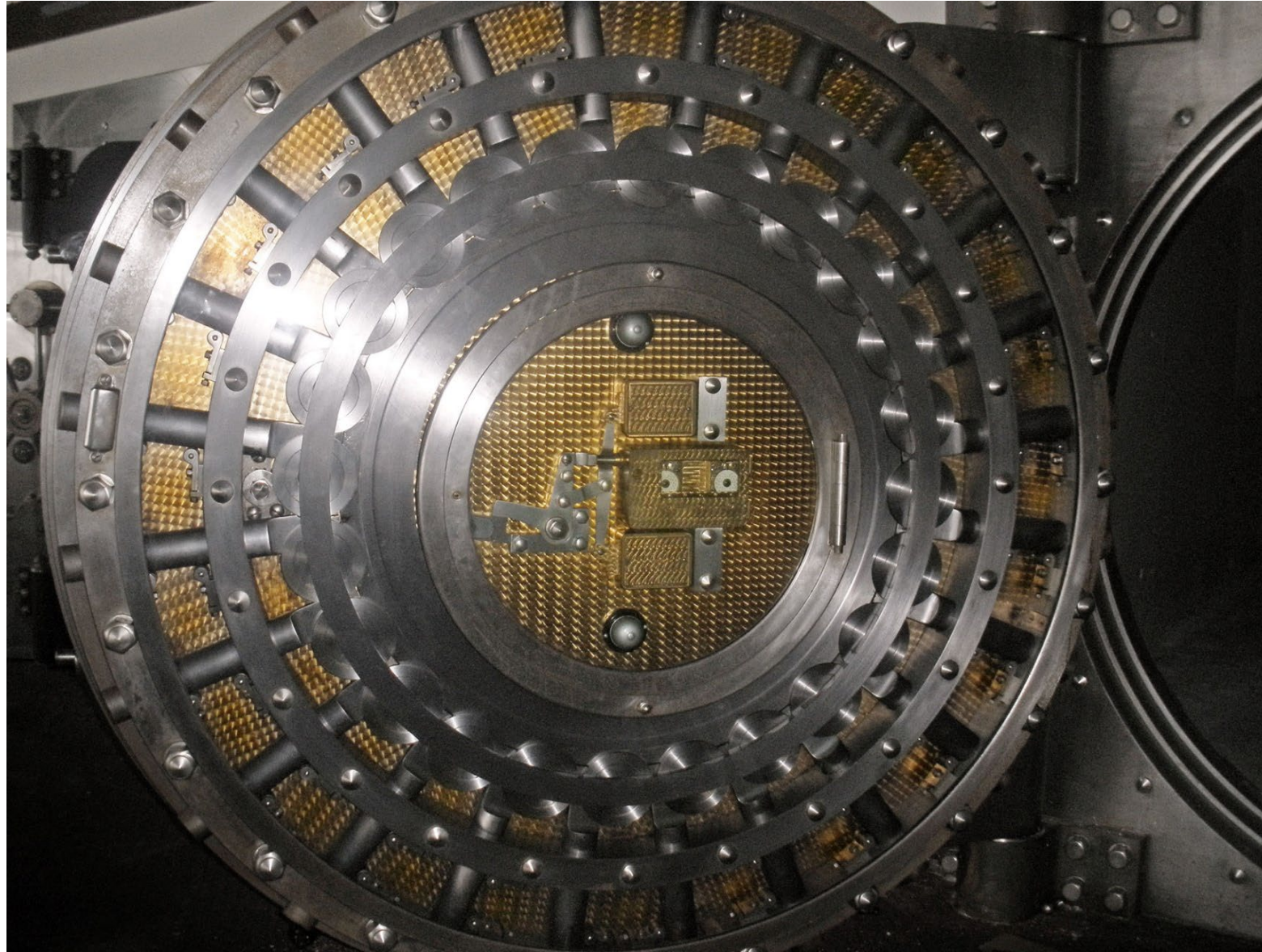

TINY LOCK BOLTS CAN CONTROL MUCH LARGER BOLTWORK



TINY LOCK BOLTS CAN CONTROL MUCH LARGER BOLTWORK

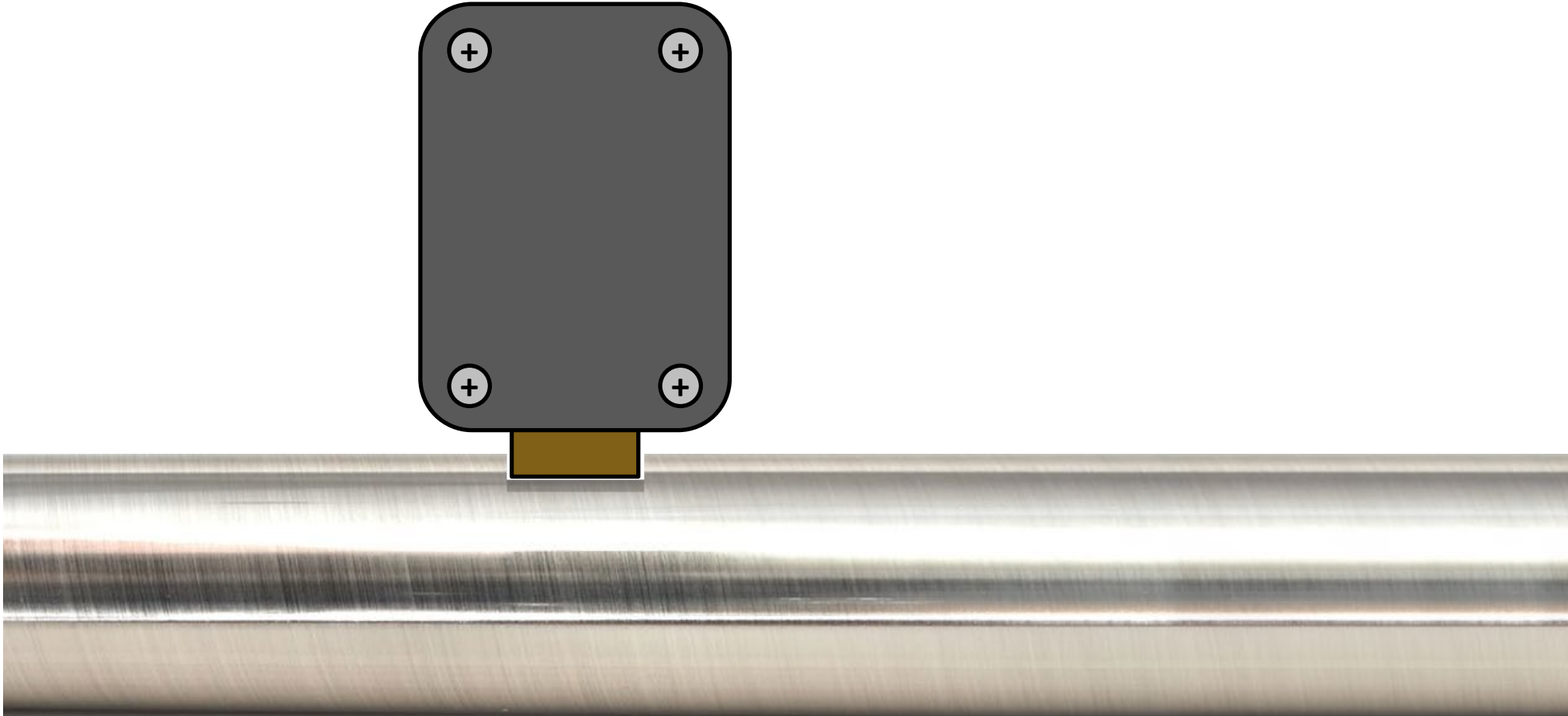

THIS IS A COMMON CAUSE OF STUCK DOORS OR DIALS

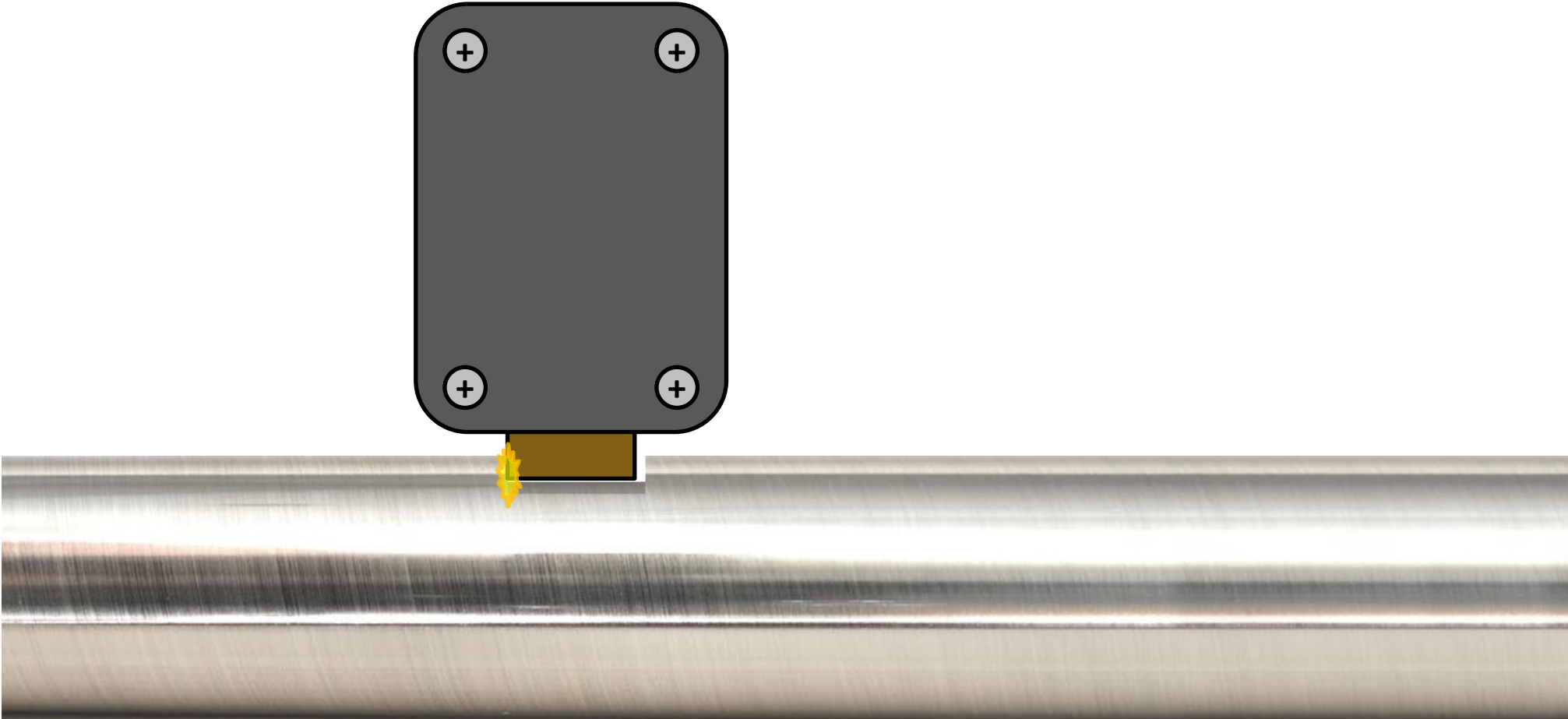

THE GOVERNMENT AND MILITARY MOVED AWAY FROM MECHANICAL SAFE LOCKS

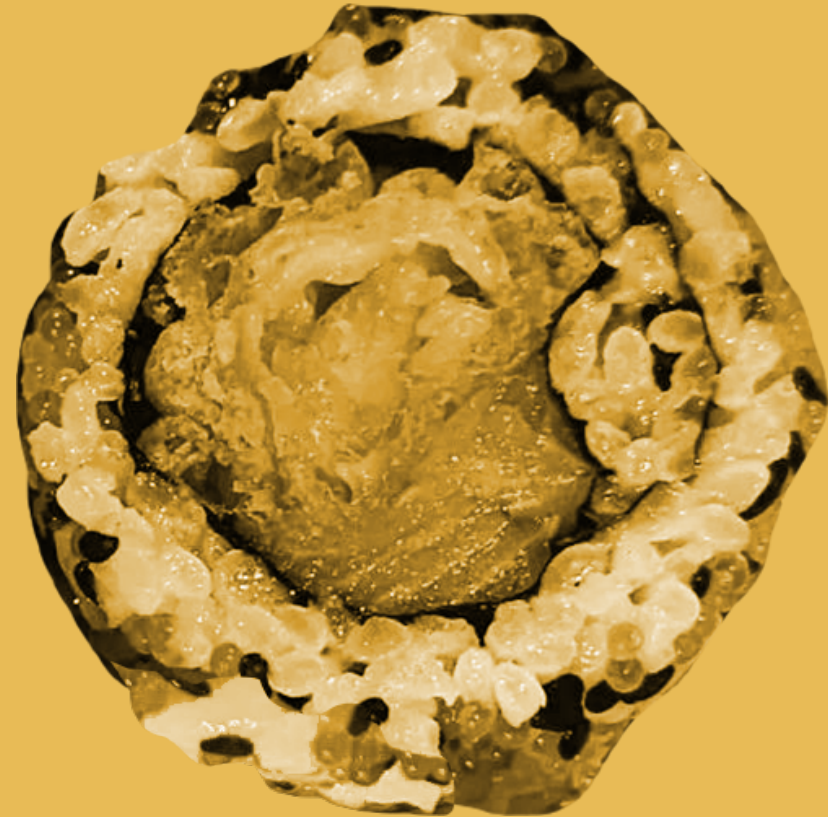

DoD LOCK PROGRAM, FEDERAL STANDARD FF-L-2740



MAS-HAMILTON X-07



MAS-HAMILTON X-08



KABA-MAS X-09



KABA-MAS X-10



DISTINGUISHING X-09 vs X-10 LOCKS



DISTINGUISHING X-09 vs X-10 LOCKS



DATE CODE IN THE
9 O'CLOCK POSITION

SAFE LOCK IS AN X-09

DISTINGUISHING X-09 vs X-10 LOCKS



DATE CODE IN THE
8 O'CLOCK POSITION

SAFE LOCK IS AN X-10

CIVILIANS HAVE ALSO BEEN ADOPTING ELECTRONIC SAFE LOCKS

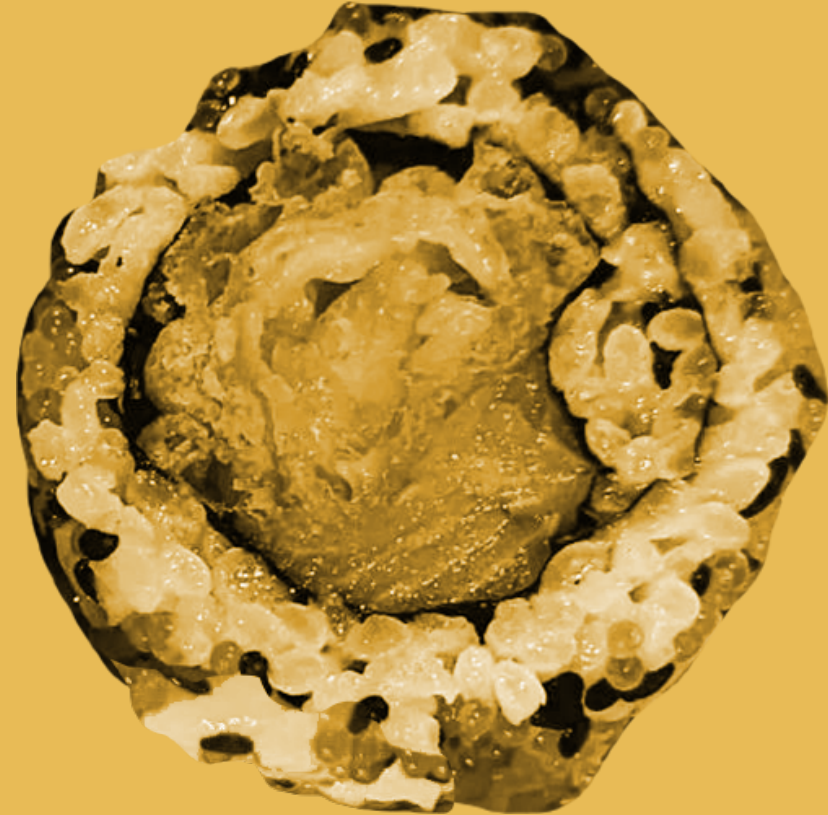

CIVILIAN ELECTRONIC SAFE LOCKS



CIVILIAN ELECTRONIC SAFE LOCKS



CIVILIAN ELECTRONIC SAFE LOCKS

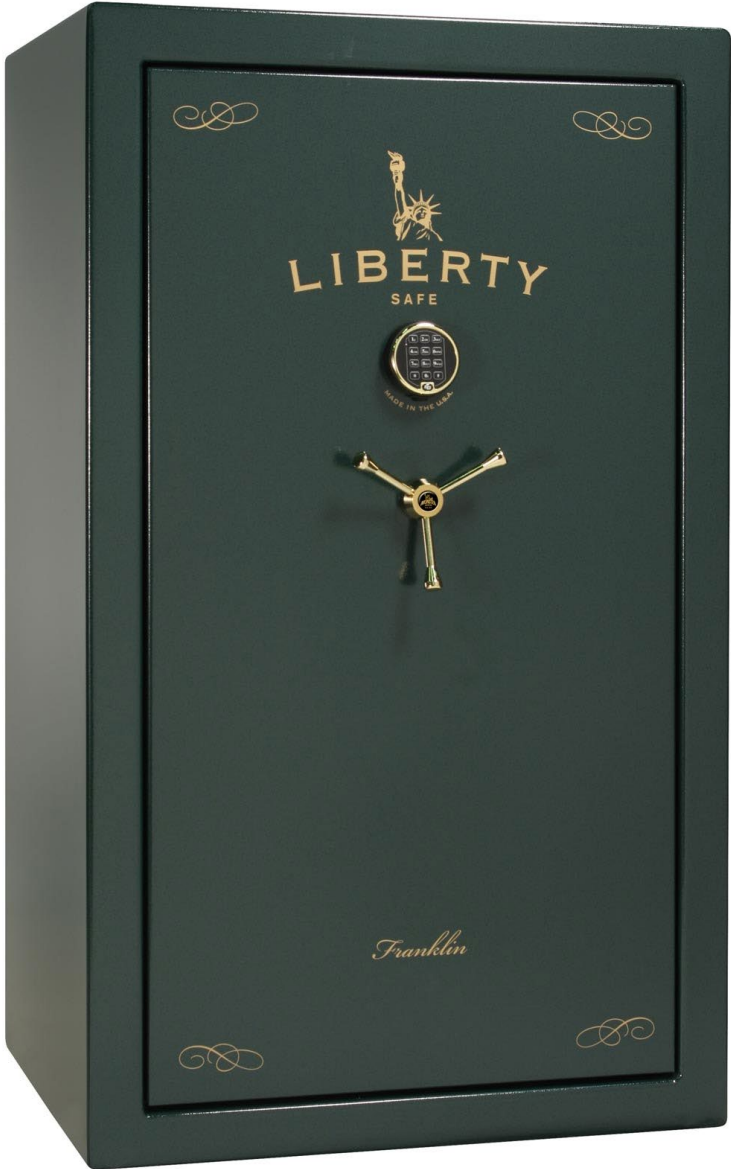

THE LIBERTY SAFE NEWS STORY

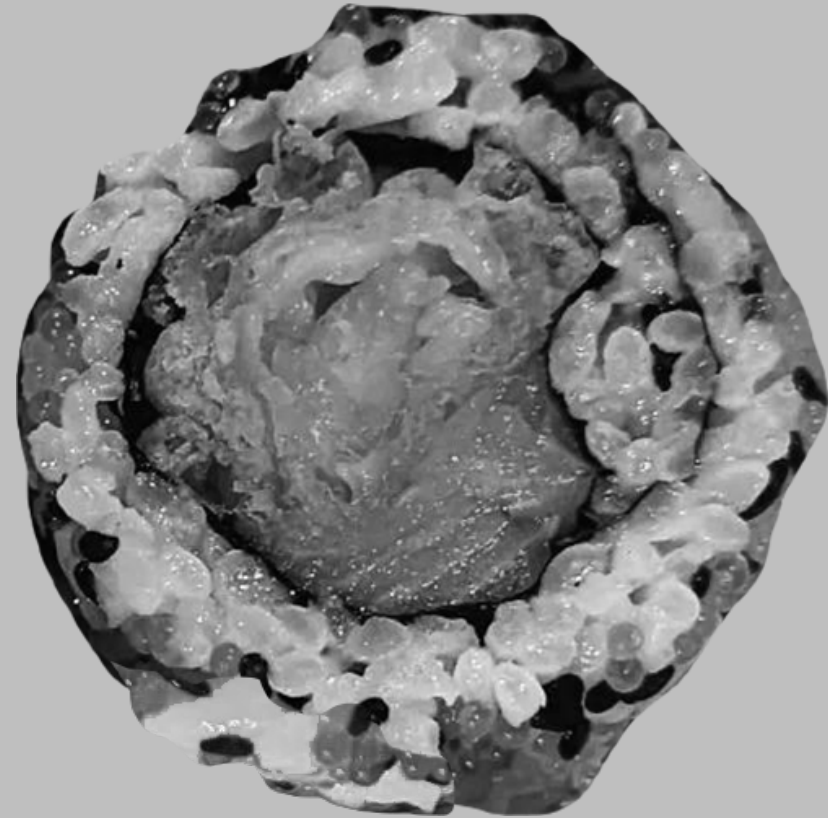

Identified by his ears, Arkansas man is arrested in Capitol riot

September 1, 2023 at 3:57 a.m.

by [Bill Bowden](#)



Nathan Hughes

A Northwest Arkansas man arrested Wednesday in connection with the U.S. Capitol riot was identified by his ears.

"Hughes' distinct notches at the top of his ears match those of the person who engaged in

violence in the Union West Tunnel on January 6, 2021," according to a statement from the FBI.

Top Jobs

Director, Data Science >
WAL-MART in Bentonville AR

Intrusion Analyst III,... >
WAL-MART in Bentonville AR

THERE WAS A KERFUFFLE



 **jny the human**  @jnyboy · 7h
Hold up.

"The feds called the manufacturer of his Liberty Gun Safe and got the passcode to get into it too."

Well that's a shitty safe. [@libertysafeinc](#) perhaps you should advertise that you have backdoored your product and freely give the codes to thieves.

 **Hodgetwins**  @hodgetwins · 11h
 Last week, a friend of ours was raided by the feds over J6, his name is Nathan Hughes and he's from Fayetteville, Arkansas. Nate was raided by the FBI and arrested at gun point. His girlfriend (who just had a miscarriage) was held at gun point and put in handcuffs. The FBI... Show more



THERE WAS A KERFUFFLE

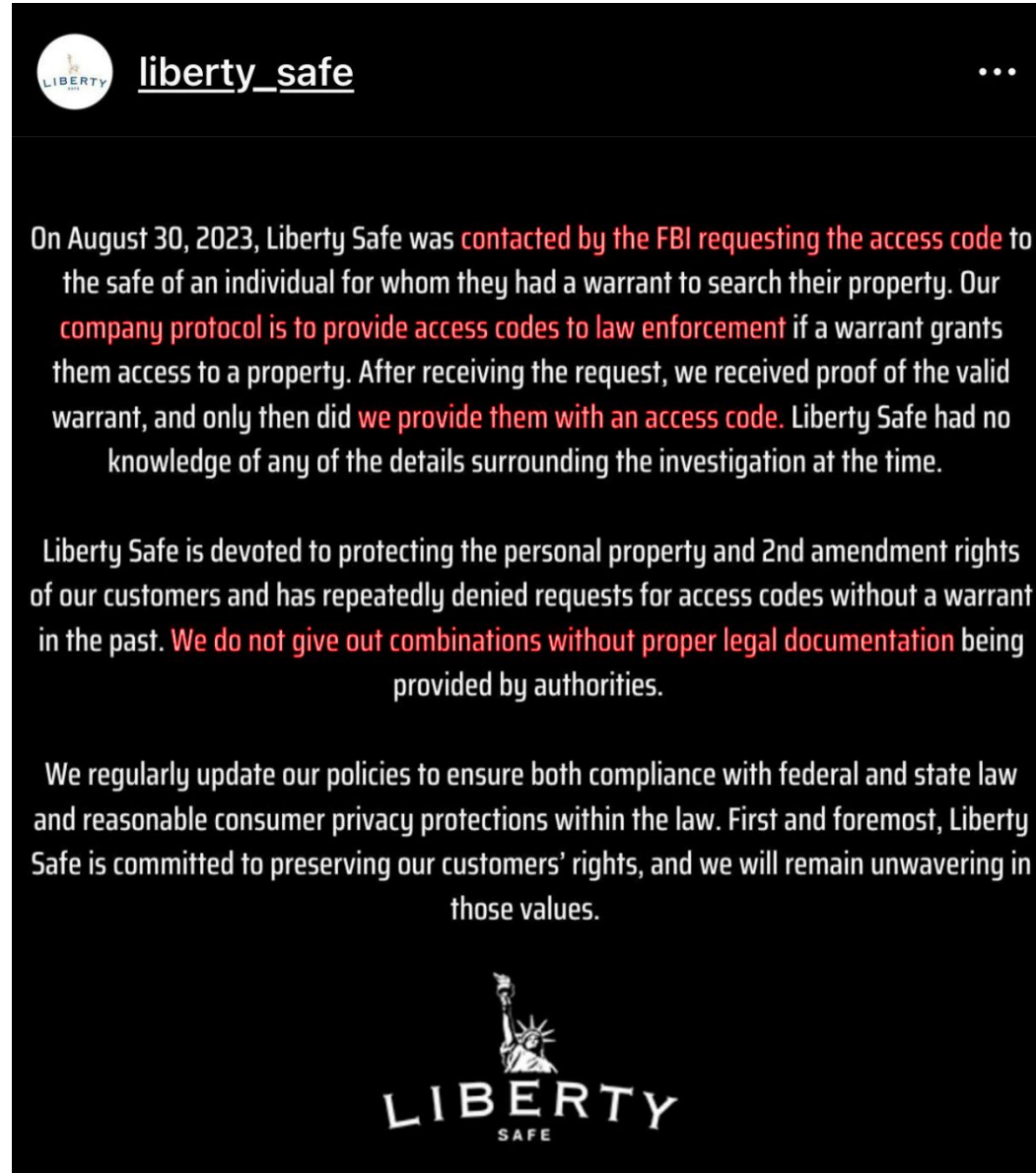

THERE WAS A KERFUFFLE

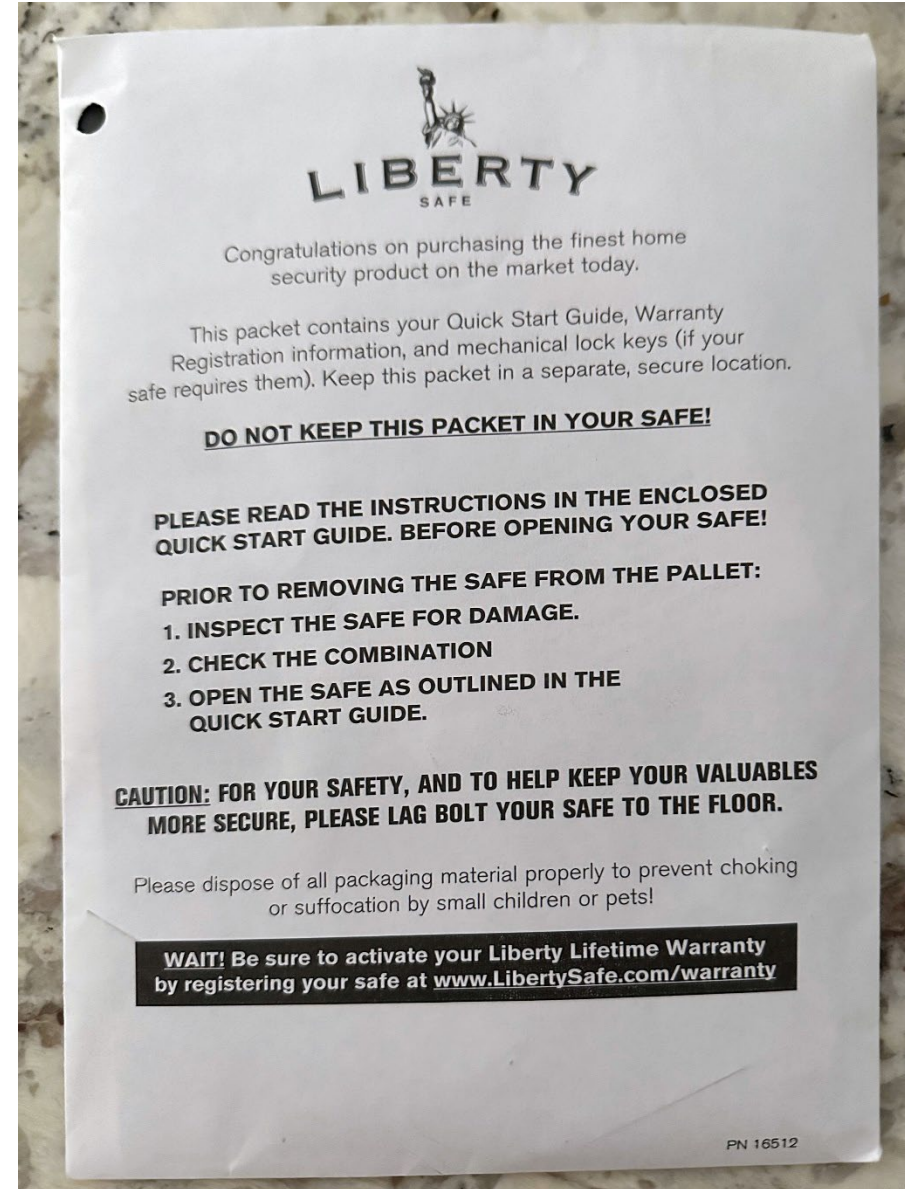
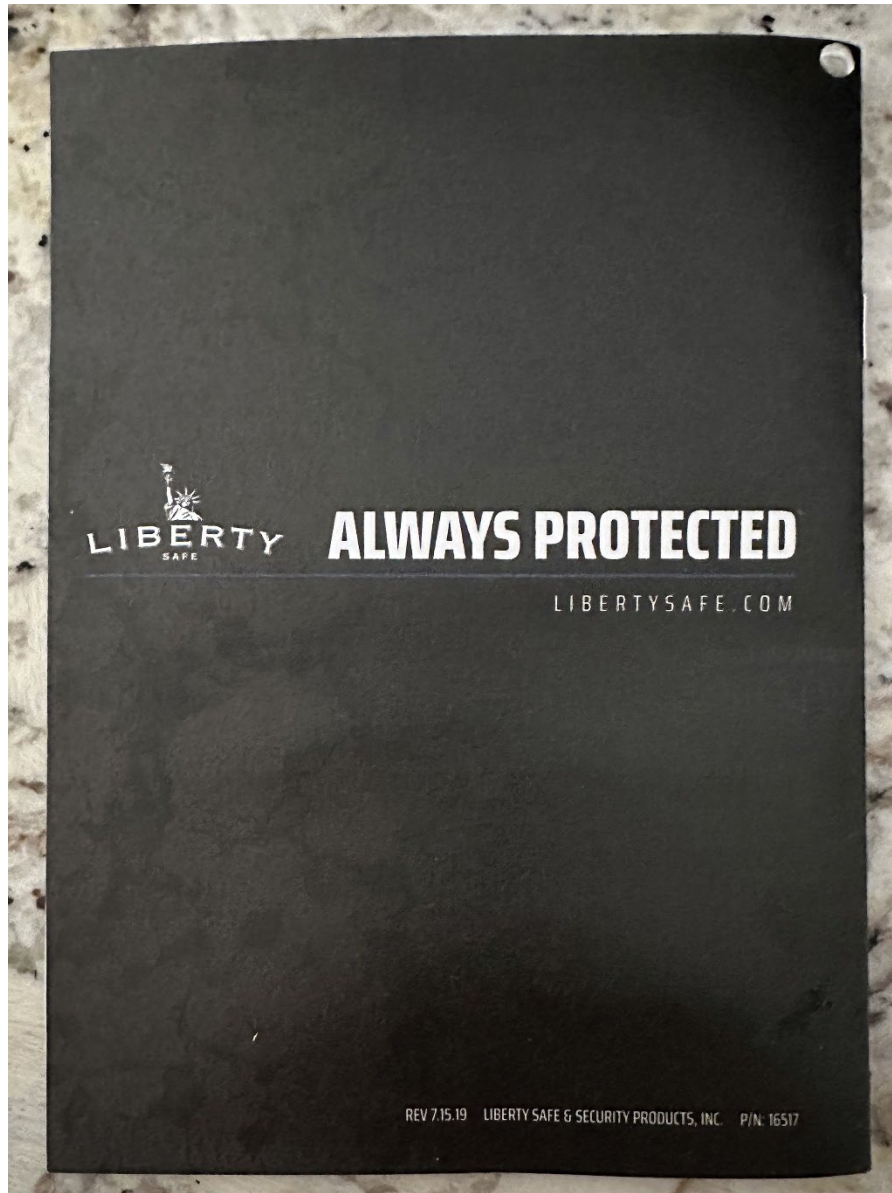

THERE WAS A KERFUFFLE

Your safe is now ready to protect your valuables. For additional instructions a full Use & Care Manual can be downloaded from our website www.libertysafe.com/ownersmanual.php. If you experienced a problem, you can consult the troubleshooting guide within the Use & Care Manual online. For additional online help visit www.libertysafe.com/services.php or contact customer service by phone (800) 247-5625. Support is available Mon-Fri, 8:00am to 5:00pm Mountain Standard Time. You will need your safe serial number when contacting customer service about your safe.

LOST COMBINATION OR KEYS

The lock on your safe has been set with a randomly selected combination at the time of manufacturing. As part of our continuing service, **a record of your combination by serial number is kept on file.** To help us better serve you, please contact Customer Support at (800) 247-5625 when you change your combination or code. If you lose your combination, you can retrieve a copy for a \$25.00 research fee, provided you have not changed it from the original combination. You must complete certain security and documentation requirements. If you lose your keys you can obtain duplicate for \$5.00 each key, plus \$5.00 shipping and handling. Go to www.libertysafe.com to download a combination/duplicate key request form.

THERE WAS A KERFUFFLE



Home

Explore

20+ Notifications

1 Messages

Lists

Communities

Verified

Profile

More

Post



Deviant Ollam 
@deviantollam



Post



Not K  @NotK_US · 15h ...
Removing the cable deprives the Securam unit of power. Wait a bit and then start pushing the hole with paperclip to further deplete any power that is there. Then hold the button with the paperclip and then plug front unit back into internal unit.

1 7 135 16.3K



Not K  @NotK_US · 15h ...
Once you have done that, the Securam will be reset back to Factory Setting. The Manager Code should be now 1-1-1-1-1-1 and the user code should be 1-2-3-4-5-6.

2 9 156 16.3K



Not K  @NotK_US · 15h ...
To change ANY CODE
Use 0-0-0-0-0-0 to start the reset process and it beeps once
Input either manager or user code and it then beeps once
Input new manager or user code and it then beeps once
To test new password, input new code and it beeps twice

3 6 168 16.3K



Not K  @NotK_US · 15h ...
If you need a video from Securam to explain this, please go to



youtube.com

Reset to factory Default - SafeLogic Series - SecuRam

Search

What's happening

US Open · LIVE

US Open Tennis 2023



#DraftKings 🏆

Bet \$5, Get \$200 in Bonus Bets

 Promoted by DraftKings Sportsbook

Trending in United States

#Seven11Erc

Trending with [Nate Davis](#)

Trending in United States

Category 4

5,673 posts

Trending

Tucker Carlson

119K posts

[Show more](#)

[Terms of Service](#) [Privacy Policy](#) [Cookie Policy](#)
[Accessibility](#) [Ads info](#) [More ...](#) © 2023 X Corp.

Messages



THERE WAS A KERFUFFLE



THERE WAS A KERFUFFLE

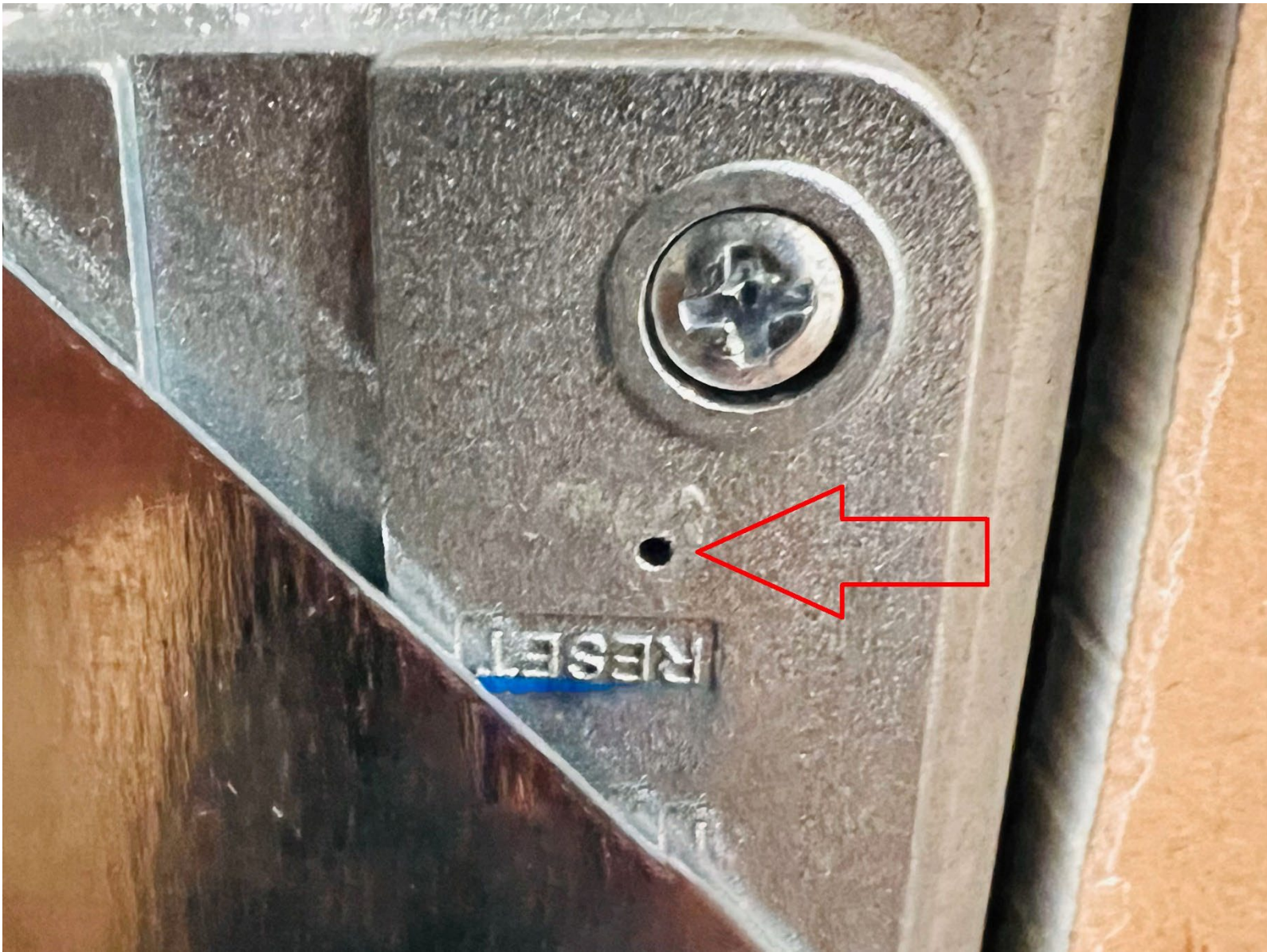

THERE WAS A KERFUFFLE

Gary's Customer Appreciation Sale! Inbox



Gary's Pawn & Gun 5:36 PM



GARY'S
•EST. 1978•

LIBERTY
SAFE

CUSTOMER APPRECIATION
SALE!
OCTOBER 2ND-21ST!
LIBERTY IS OFFERING REBATES
UP TO \$500! AND JUST FOR OUR
CUSTOMERS, GARY'S IS
MATCHING THE REBATE!

THERE WAS A KERFUFFLE



THERE WAS A KERFUFFLE



Find a Distributor

Product Resources

- Documents & Specs
- Instructions
- Q&A
- Part Numbers
- Certifications

Product Applications

- Residential



Product Catalog

THERE WAS A KERFUFFLE



Use the Management Reset Code to reset my lock?

[Home](#) / [Q&A Resources](#) /

The Management Reset code (MRC) is a 7 digit code. The 2 numbers in the MRC that are separated by a "/" or are in "[]" have to be entered simultaneously - press both numbers at the same time.

Execute the MRC sequence using the following steps:

1. Press * 6 #
2. Now enter the MRC
3. After entering the MRC, press #

You will hear 1 beep for each time the MRC has been executed. (If this is the first time that the MRC has been executed, you will hear only 1 beep.)

EX: *6# 135 0/1 87 #

The Master Code has now been reset to the Factory Default of 123456#
Enter the Master Code 123456#, and the lock will open.

Applicable to:

6120, 6123, Z02 Locks

Related Products

[Model 6120](#) [Electronic Safe Lock](#)

[Model 6123](#) [Electronic Safe Lock](#)

LOCKSMITHS & SAFE TECHS HAVE KNOWN THIS FOR A LONG TIME

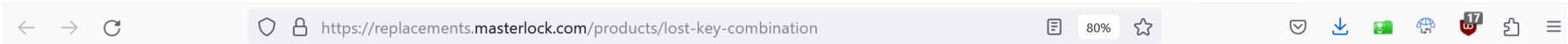

Let's Get Started

[Where do I find my model number, key number or serial number?](#)

(*) Required Fields

*Model Number

*Key (Lock) Number

If you can't identify the key number by viewing the key or lock, please contact customer care at 1-800-828-1438 to proceed.

*Serial Number

*Select how many keys you would like

- 2 Keys: \$29.95 (USD) plus applicable taxes
- 4 Keys: \$59.90 (USD) plus applicable taxes

Select A Processing Option

- Standard Processing 7-10 Days: \$29.95 (USD) plus applicable taxes

How Would You Like Your Combination To Be Sent To You?

- Send to my Email Address

*Email Address

*Confirm Email Address

Note

This website is only for customers in the contiguous United States. Customers in Canada should visit our [Canadian website](#). Customers in Europe should visit our [European website](#). If you live in another area, please contact [customer service](#).

Process And Costs – Standard Key & Combination Orders

Once your request has been received, it can take up to 7–10 business days for processing before your replacement key & combination is mailed to you. There is a (USD) non-refundable charge for all replacement requests.

For Expedited Key Orders

Please call customer service at 1-800-828-1438. Orders received before 11am Central time, Monday-Friday 8:30am-5pm, will ship the same day for next-day delivery. Cost for expedited key orders is \$44.95 per set only (2 keys), plus applicable sales tax, by credit card only.

Tax Exempt

Tax exempt customers should [contact Customer Service](#).

MANY OF YOU REACHED OUT TO ME



~~404~~

SIGN IN

SUBSCRIBE

Massively Popular Safe Locks Have Secret Backdoor Codes

Senator Ron Wyden has found that the DoD banned the use of such locks for U.S. government systems, but deliberately kept information about the backdoors from the public.

JOSEPH COX · MAR 13, 2024 AT 9:00 AM



MANY OF YOU REACHED OUT TO ME



404

SIGN OUT

ACCOUNT

Two of the biggest manufacturers of locks used in commercial safes have been accused of essentially putting backdoors in at least some of their products in a new letter by Senator Ron Wyden. Wyden is urging the U.S. government to explicitly warn the public about the vulnerabilities, which Wyden says could be exploited by foreign adversaries to steal what U.S. businesses store in safes, such as trade secrets.

The little known “manufacturer” or “manager” reset codes could let third parties—such as spies or criminals—bypass locks without the owner’s consent and are sometimes not disclosed to customers. Wyden’s office also found that while the U.S. Department of Defense (DoD) bans such locks for sensitive and classified U.S. government use in part due to the security vulnerability reset codes pose, the government has deliberately not warned the public about the existence of these backdoors.

The specific companies named in Wyden’s letter are China-based SECURAM and U.S.-based Sargent and Greenleaf (S&G). Each produces keypad locks which are then implemented into safes by other manufacturers. The full list of locks that contain backdoor codes is unknown, but documentation available online points to multiple SECURAM products which do include them, and S&G confirmed to Wyden’s office that some of its own locks also have similar codes.

Become a paid subscriber for unlimited, ad-free articles and access to bonus content. This site is funded by subscribers and you will be directly powering our journalism.

The findings produce clarity on sometimes-hidden features inside widely popular physical locks. They also provide an analogy to the discussion around encryption backdoors. For decades, governments, tech companies, and members of civil society have clashed over multiple lobbying attempts by agencies to have backdoors inserted into technology, and in particular, encryption products. The fact the DoD protected its own interests while not warning the public gives a stark demonstration of what could happen if a backdoor was inserted into a consumer electronics device or similar.

MANY OF YOU REACHED OUT TO ME



MANY OF YOU REACHED OUT TO ME



The documentation also explicitly says that sometimes the existence of a manager code may not be sent to an actual user of the device. "In some instances the Manager Code and associated Operating Instructions are not issued to the End User," it reads, meaning that people may be using these locks without understanding that they can include a backdoor code.

Government and Law Enforcement Requests. S&G policy is to comply with all lawful requests served *directly* on S&G by government agencies and law enforcement pursuant to a lawfully executed and proper warrant, subpoena or court order. S&G will only provide information in response to such lawful requests with a showing of probable cause, or when provided with Consumer or Customer consent, as applicable. S&G carefully reviews all such requests to ensure that there is a valid legal basis for each request, including consulting with legal counsel as appropriate. Once confirmed, S&G complies with legally valid requests. Where S&G determines that there is no valid legal basis or where a request is considered to be unclear, inappropriate or overly broad, S&G will object, challenge or reject the request.

A SCREENSHOT OF S&G'S DATA POLICY.

Deviant Ollam, an information security professional who says they have used backdoor lock codes as part of their work, told 404 Media in an email that "While the security landscape consists of a myriad of competing incentives and policy seldom comes in one-size-fits-all statements, I do think that the end users of any security product—whether hardware or software—should be fully aware of any backdoors, override codes, or routes of access which may exist in addition to their user key or code." This is so the users can weigh up the various factors, and potential downfalls and benefits, of a backdoor themselves.

They said they've used the codes as a safe technician offering lockout support to customers, as well as in their "covert entry work." Information security professionals often perform physical penetration tests on businesses to survey a client's defenses. "Contacting manufacturers with the serial number of a target's safe in order to be sent the code for a small fee has saved me time and effort during penetration engagements," they added.

"It is safe to say that the majority of electronic safe locks marketed to home consumers and small businesses contain one or more type of backdoor code," they continued. Sometimes these are disclosed to users, "but the overwhelming

MANY OF YOU REACHED OUT TO ME

RON WYDEN
OREGON

CHAIRMAN OF COMMITTEE ON
FINANCE

221 DIRKSEN SENATE OFFICE BUILDING
WASHINGTON, DC 20510
(202) 224-5244

United States Senate
WASHINGTON, DC 20510-3703

COMMITTEES:
COMMITTEE ON FINANCE
COMMITTEE ON THE BUDGET
COMMITTEE ON ENERGY AND NATURAL RESOURCES
SELECT COMMITTEE ON INTELLIGENCE
JOINT COMMITTEE ON TAXATION

RON WYDEN
OREGON

CHAIRMAN OF COMMITTEE ON
FINANCE

221 DIRKSEN SENATE OFFICE BUILDING
WASHINGTON, DC 20510
(202) 224-5244

United States Senate
WASHINGTON, DC 20510-3703

COMMITTEES:
COMMITTEE ON FINANCE
COMMITTEE ON THE BUDGET
COMMITTEE ON ENERGY AND NATURAL RESOURCES
SELECT COMMITTEE ON INTELLIGENCE
JOINT COMMITTEE ON TAXATION

March 13, 2024

The Honorable Michael C. Casey
Director
National Counterintelligence and Security Center
LX/ICC-B
Washington, DC 20511

Dear Mr. Casey:

I write to urge the National Counterintelligence and Security Center (NCSC) to warn American businesses about the counterintelligence risks posed by commercial safe locks that do not meet U.S. government security standards.

Many commercially available safes include electronic locks that can also be unlocked using special codes set by and known only to the manufacturer. The existence of these “manufacturer reset” or “management reset” codes is not prominently advertised to consumers, nor the fact that lock manufacturers receive demands from government agencies for those codes. These backdoor codes can be exploited by foreign adversaries to steal sensitive information that U.S. businesses store in safes, such as trade secrets and other intellectual property.

The Department of Defense (DoD), which is responsible for overseeing the standards for locks and safes used to store sensitive and classified U.S. government information, informed my office by email on November 8, 2023, that manufacturer reset codes pose a security threat and, consequently, are prohibited in the locks approved for U.S. government use. DoD also provided my staff with the attached white paper on December 15, 2023, revealing that U.S. government standards for approved locks do not explicitly reference these backdoor codes in order to avoid tipping off the public to their existence. In short, the government has opted to keep the public in the dark about this vulnerability, after quietly protecting government agencies from it.

It would be one thing if these backdoors were only available to U.S. government agencies, but they are not. China-based SECURAM Systems is one of the largest manufacturers of electronic safe locks sold in the U.S. Although DoD has informed my office that the company’s products are not approved for U.S. government use, its low-cost products have enabled the firm to dominate the consumer-focused portion of the market. Technical documents published on the company’s website confirm that its products include manufacturer reset codes, and also indicate that in some cases, consumers may not be told about the existence of these codes. As a China-

headquartered company, SECURAM is of course obligated to follow Chinese law, including the requirement to cooperate with secret demands for surveillance assistance. Consequently, SECURAM could be forced to share codes with the Chinese government that would enable surreptitious or clandestine access to the safes used by U.S. businesses.

SECURAM’s primary U.S.-based competitor, Sargent and Greenleaf (S&G), has confirmed that many of its products include manufacturer reset codes, and that it can be forced to turn over those, both to the government and to civil litigants. The company provided my office with its written policy governing such disclosures, which is also attached. But of course, those codes are also a juicy target for hacking or espionage. Indeed, that is why the only S&G products that are approved to store U.S. government secrets do not feature such backdoor codes.

The NCSC plays an important role in warning U.S. businesses about the espionage threat posed by foreign spies. But U.S. businesses cannot protect their valuable intellectual property, and consequently, America’s global economic edge, from foreign espionage if they are kept in the dark about vulnerabilities in the safe locks they use. To that end, I urge the NCSC to update its public educational materials to recommend that businesses upgrade their safe locks to those that meet U.S. government security standards.

Thank you for your attention to this important matter. If you have any questions about this request, please contact Chris Soghoian in my office.

Sincerely,

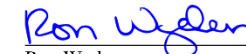

Ron Wyden
United States Senator

911 NE 11TH AVENUE
SUITE 630
PORTLAND, OR 97232
(503) 326-7525

405 EAST 8TH AVE.
SUITE 2020
EUGENE, OR 97401
(541) 431-0229

SAC ANNEX BUILDING
105 FR ST
SUITE 201
LA GRANGE, OR 97850
(541) 962-7691

U.S. COURTHOUSE
310 WEST 6TH ST
ROOM 118
MEDFORD, OR 97501
(541) 858-5122

THE JAMISON BUILDING
131 NW HAWTHORNE AVE.
SUITE 107
BEND, OR 97701
(541) 330-9142

707 13TH ST, SE
SUITE 285
SALEM, OR 97301
(503) 589-4655

911 NE 11TH AVENUE
SUITE 630
PORTLAND, OR 97232
(503) 326-7525

405 EAST 8TH AVE.
SUITE 2020
EUGENE, OR 97401
(541) 431-0229

SAC ANNEX BUILDING
105 FR ST
SUITE 201
LA GRANGE, OR 97850
(541) 962-7691

U.S. COURTHOUSE
310 WEST 6TH ST
ROOM 118
MEDFORD, OR 97501
(541) 858-5122

THE JAMISON BUILDING
131 NW HAWTHORNE AVE.
SUITE 107
BEND, OR 97701
(541) 330-9142

707 13TH ST, SE
SUITE 285
SALEM, OR 97301
(503) 589-4655

[HTTPS://WYDEN.SENATE.GOV](https://wyden.senate.gov)
PRINTED ON RECYCLED PAPER

[HTTPS://WYDEN.SENATE.GOV](https://wyden.senate.gov)
PRINTED ON RECYCLED PAPER

MANY OF YOU REACHED OUT TO ME

RON WYDEN
OREGON

CHAIRMAN OF COMMITTEE ON
FINANCE

221 DIRKSEN SENATE OFFICE BUILDING
WASHINGTON, DC 20510
(202) 224-5244

United States Senate
WASHINGTON, DC 20510-3703

COMMITTEES:
COMMITTEE ON FINANCE
COMMITTEE ON THE BUDGET
COMMITTEE ON ENERGY AND NATURAL RESOURCES
SELECT COMMITTEE ON INTELLIGENCE
JOINT COMMITTEE ON TAXATION

RON WYDEN
OREGON

CHAIRMAN OF COMMITTEE ON
FINANCE

221 DIRKSEN SENATE OFFICE BUILDING
WASHINGTON, DC 20510
(202) 224-5244

United States Senate
WASHINGTON, DC 20510-3703

COMMITTEES:
COMMITTEE ON FINANCE
COMMITTEE ON THE BUDGET
COMMITTEE ON ENERGY AND NATURAL RESOURCES
SELECT COMMITTEE ON INTELLIGENCE
JOINT COMMITTEE ON TAXATION

March 13, 2024

The Honorable Michael C. Casey
Director
National Counterintelligence and Security Center
LX/ICC-B
Washington, DC 20511

Dear Mr. Casey:

I write to urge the National Counterintelligence and Security Center (NCSC) to warn American businesses about the counterintelligence risks posed by commercial safe locks that do not meet U.S. government security standards.

Many commercially available safes include electronic locks that can also be unlocked using special codes set by and known only to the manufacturer. The existence of these “manufacturer reset” or “management reset” codes is not prominently advertised to consumers, nor the fact that lock manufacturers receive demands from government agencies for those codes. These backdoor codes can be exploited by foreign adversaries to steal sensitive information that U.S. businesses store in safes, such as trade secrets and other intellectual property.

The Department of Defense (DoD), which is responsible for overseeing the standards for locks and safes used to store sensitive and classified U.S. government information, informed my office by email on November 8, 2023, that manufacturer reset codes pose a security threat and, consequently, are prohibited in the locks approved for U.S. government use. DoD also provided my staff with the attached white paper on December 15, 2023, revealing that U.S. government standards for approved locks do not explicitly reference these backdoor codes in order to avoid tipping off the public to their existence. In short, the government has opted to keep the public in the dark about this vulnerability, after quietly protecting government agencies from it.

It would be one thing if these backdoors were only available to U.S. government agencies, but they are not. China-based SECURAM Systems is one of the largest manufacturers of electronic safe locks sold in the U.S. Although DoD has informed my office that the company’s products are not approved for U.S. government use, its low-cost products have enabled the firm to dominate the consumer-focused portion of the market. Technical documents published on the company’s website confirm that its products include manufacturer reset codes, and also indicate that in some cases, consumers may not be told about the existence of these codes. As a China-

headquartered company, SECURAM is of course obligated to follow Chinese law, including the requirement to cooperate with secret demands for surveillance assistance. Consequently, SECURAM could be forced to share codes with the Chinese government that would enable surreptitious or clandestine access to the safes used by U.S. businesses.

SECURAM’s primary U.S.-based competitor, Sargent and Greenleaf (S&G), has confirmed that many of its products include manufacturer reset codes, and that it can be forced to turn over those, both to the government and to civil litigants. The company provided my office with its written policy governing such disclosures, which is also attached. But of course, those codes are also a juicy target for hacking or espionage. Indeed, that is why the only S&G products that are approved to store U.S. government secrets do not feature such backdoor codes.

The NCSC plays an important role in warning U.S. businesses about the espionage threat posed by foreign spies. But U.S. businesses cannot protect their valuable intellectual property, and consequently, America’s global economic edge, from foreign espionage if they are kept in the dark about vulnerabilities in the safe locks they use. To that end, I urge the NCSC to update its public educational materials to recommend that businesses upgrade their safe locks to those that meet U.S. government security standards.

Thank you for your attention to this important matter. If you have any questions about this request, please contact Chris Soghoian in my office.

Sincerely,

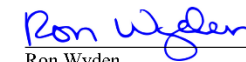
Ron Wyden
United States Senator

911 NE 11TH AVENUE
SUITE 630
PORTLAND, OR 97232
(503) 326-7525

405 EAST 8TH AVE.
SUITE 2020
EUGENE, OR 97401
(541) 431-0229

SAC ANNEX BUILDING
105 FR ST
SUITE 201
LA GRANGE, OR 97850
(541) 962-7691

U.S. COURTHOUSE
310 WEST 6TH ST
ROOM 118
MEDFORD, OR 97501
(541) 858-5122

THE JAMISON BUILDING
131 NW HAWTHORNE AVE.
SUITE 107
BEND, OR 97701
(541) 330-9142

707 13TH ST, SE
SUITE 285
SALEM, OR 97301
(503) 589-4655

[HTTPS://WYDEN.SENATE.GOV](https://wyden.senate.gov)
PRINTED ON RECYCLED PAPER

911 NE 11TH AVENUE
SUITE 630
PORTLAND, OR 97232
(503) 326-7525

405 EAST 8TH AVE.
SUITE 2020
EUGENE, OR 97401
(541) 431-0229

SAC ANNEX BUILDING
105 FR ST
SUITE 201
LA GRANGE, OR 97850
(541) 962-7691

U.S. COURTHOUSE
310 WEST 6TH ST
ROOM 118
MEDFORD, OR 97501
(541) 858-5122

THE JAMISON BUILDING
131 NW HAWTHORNE AVE.
SUITE 107
BEND, OR 97701
(541) 330-9142

707 13TH ST, SE
SUITE 285
SALEM, OR 97301
(503) 589-4655

[HTTPS://WYDEN.SENATE.GOV](https://wyden.senate.gov)
PRINTED ON RECYCLED PAPER

MANY OF YOU REACHED OUT TO ME

Sargent & Greenleaf, Inc.

Security Device Access and Legal Process Policy

General Information. Sargent & Greenleaf, Inc. (“S&G”) designs, manufactures, and markets locks and other security devices and mechanisms (“Security Devices”). S&G sells its products to manufacturers that incorporate Security Devices into a wide range of products, including traditional safes for documents and valuables, firearm safes, ATM safes and lock boxes. S&G also sells products through distributors who in turn sell to locksmiths and in some cases individuals (collectively, these manufacturers, distributors, and individuals are “S&G Customers” or “Customers”). Individual consumers are usually customers of S&G Customers (“Consumers”) and may possess a Security Device as a result of purchasing a Customer’s product into which a Security Device has been installed by the S&G Customer.

Security Device Access Information. It is S&G policy that any access to or methods by which to operate any Security Devices installed in Customer products takes place solely at the discretion of S&G Customers and pursuant to any agreements between S&G Customers and any Consumers.

- S&G does not possess any Consumer’s individual access code for any Security Device installed on a Customer product owned or possessed by that same Consumer.
- S&G does not maintain a manifest of which individual Consumers own products fitted with its Security Devices.

Certain Security Devices are designed with manufacturer override/reset codes as a means to assist Consumers and their family members if the security code is lost.

Government and Law Enforcement Requests. S&G policy is to comply with all lawful requests served *directly* on S&G by government agencies and law enforcement pursuant to a lawfully executed and proper warrant, subpoena or court order. S&G will only provide information in response to such lawful requests with a showing of probable cause, or when provided with Consumer or Customer consent, as applicable. S&G carefully reviews all such requests to ensure that there is a valid legal basis for each request, including consulting with legal counsel as appropriate. Once confirmed, S&G complies with legally valid requests. Where S&G determines that there is no valid legal basis or where a request is considered to be unclear, inappropriate or overly broad, S&G will object, challenge or reject the request.

Private Party Requests. For private party requests, S&G complies with the laws pertaining to such requests, subject to the terms and conditions of any Customer contract, any executed subpoena or court order, and applicable law.

Customer Notice. S&G will request that its Customer notify the end use Consumer when access to the S&G Security Device is being sought in response to legal process from government, law enforcement, or third parties, except where providing notice is explicitly prohibited by the legal process itself, by a court order S&G receives, by applicable law or where S&G, in its sole discretion, believes that providing notice creates a risk of injury or death to an identifiable individual, or where notice is not applicable to the underlying facts of the case.

Contact and Requests. Any questions regarding S&G’s practices in this area can be directed to S&G at support@sargentandgreenleaf.com. Any requests for information can be formally served on S&G at S&G’s corporate office located at One Security Drive, Nicholasville, Kentucky 40356.



NON-MANUFACTURER BACKDOORS

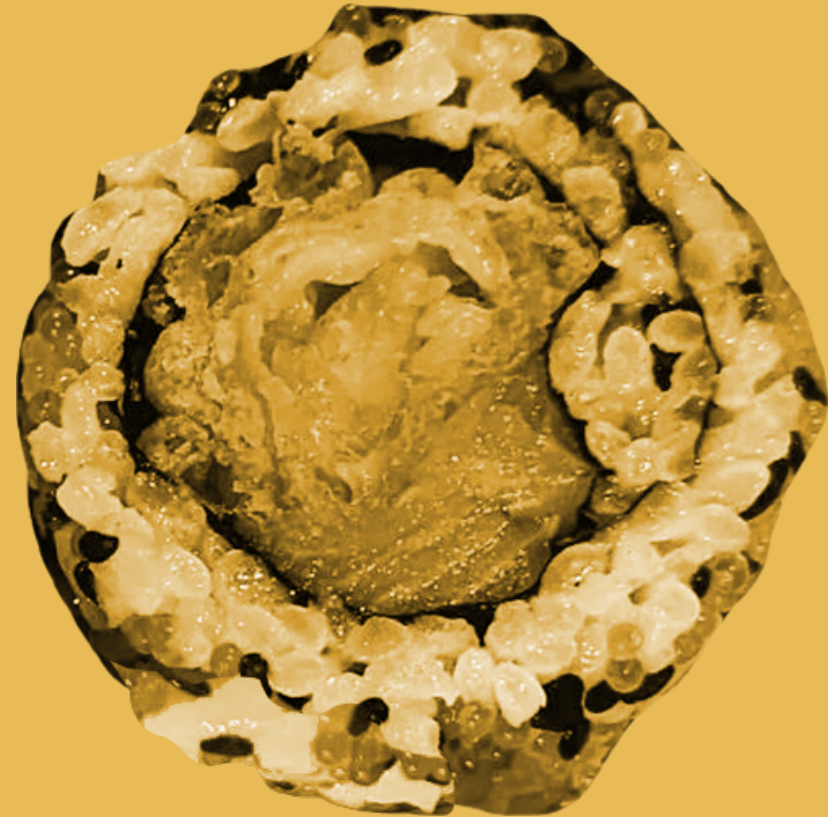

DIFFERENTIAL POWER ANALYSIS

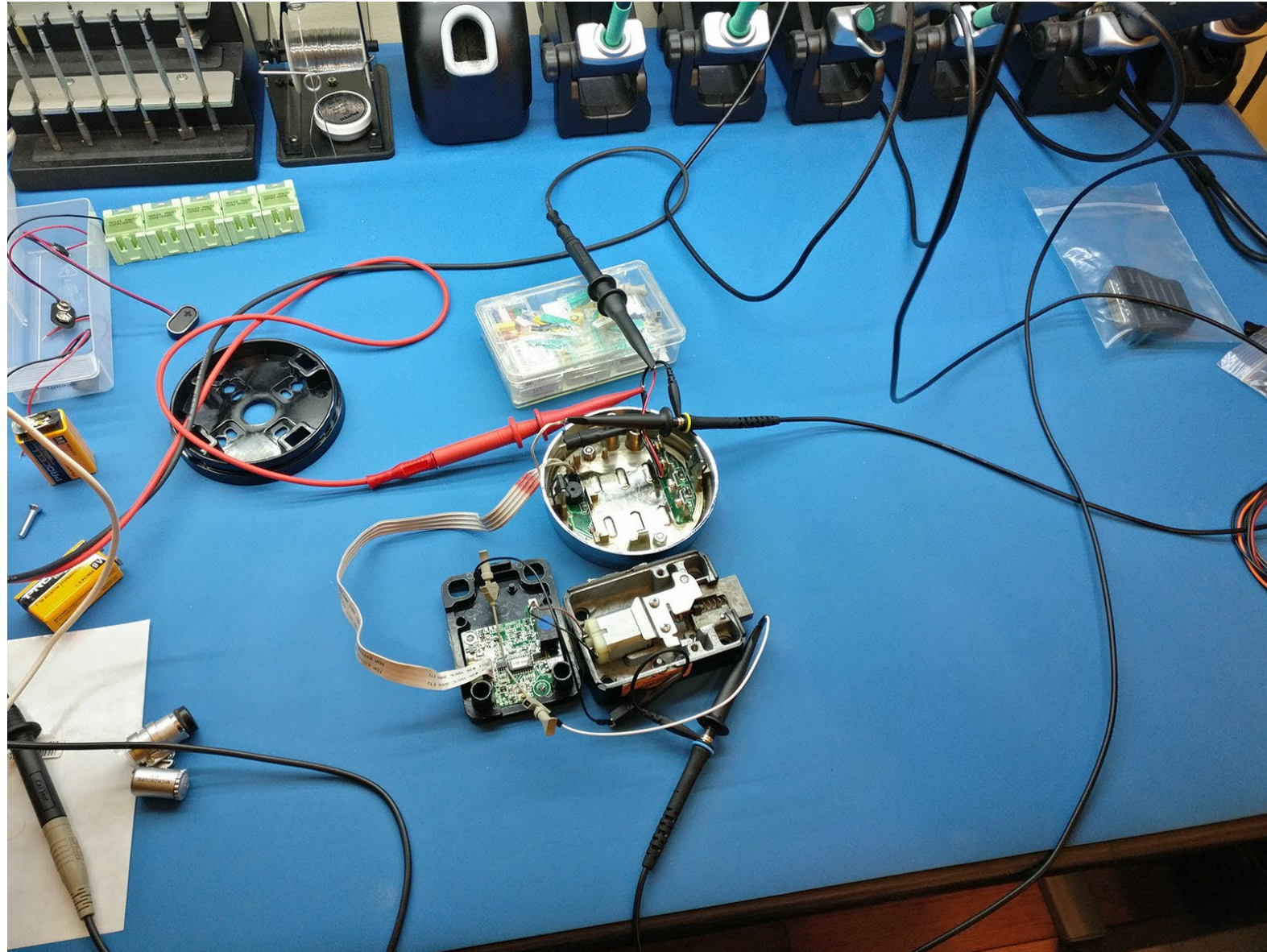

DIFFERENTIAL POWER ANALYSIS



DIFFERENTIAL POWER ANALYSIS

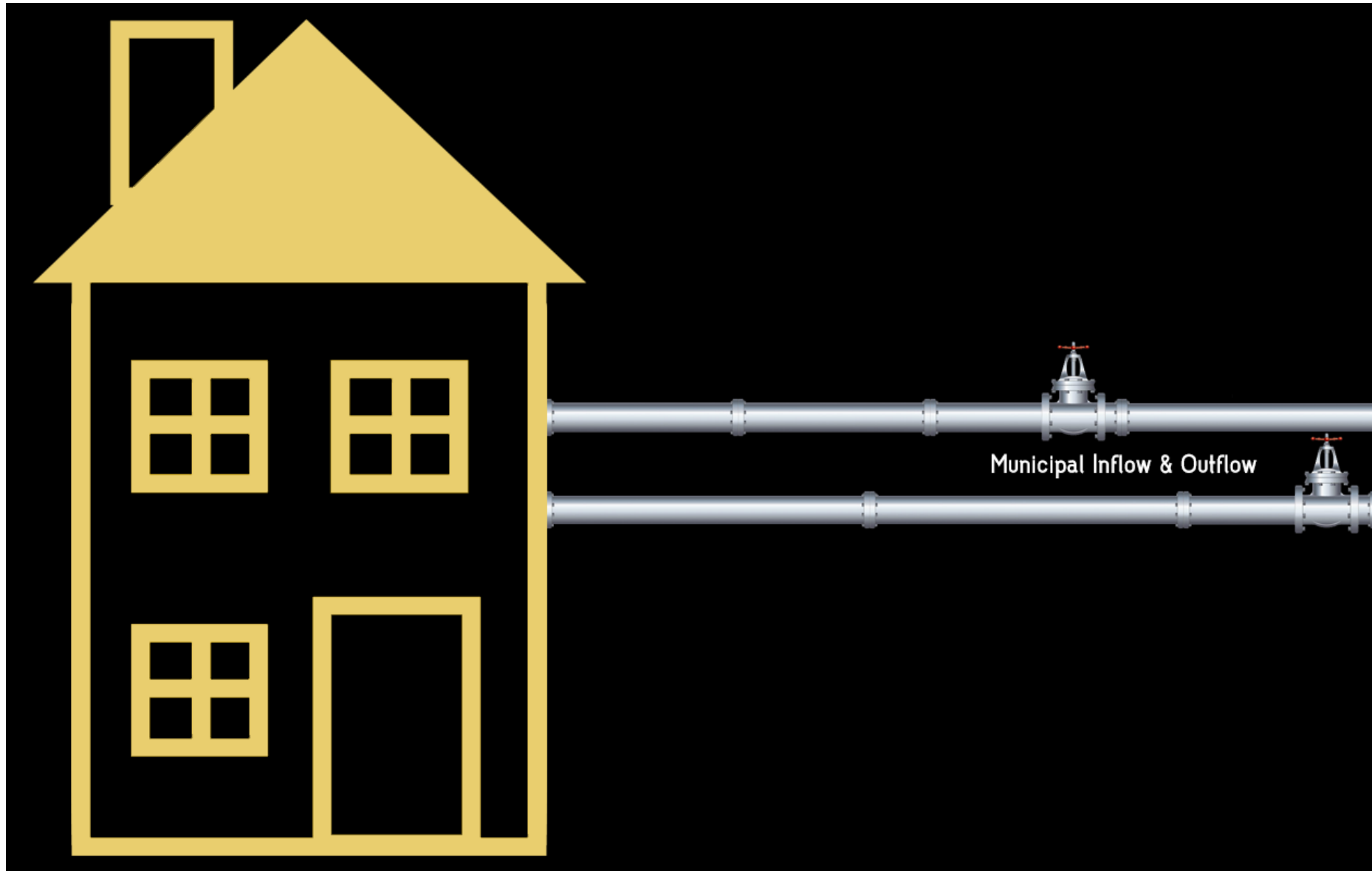

DIFFERENTIAL POWER ANALYSIS

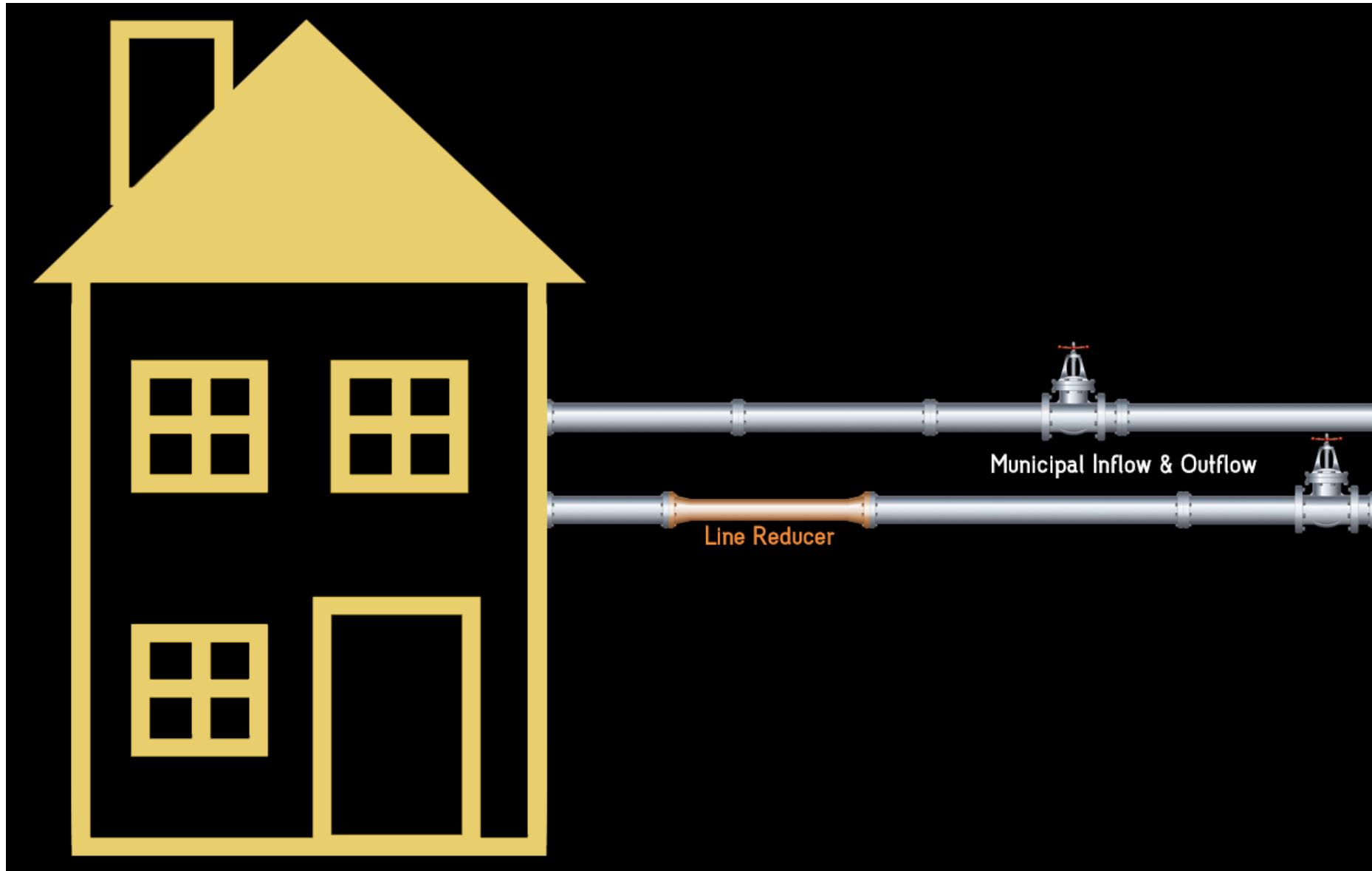

DIFFERENTIAL POWER ANALYSIS

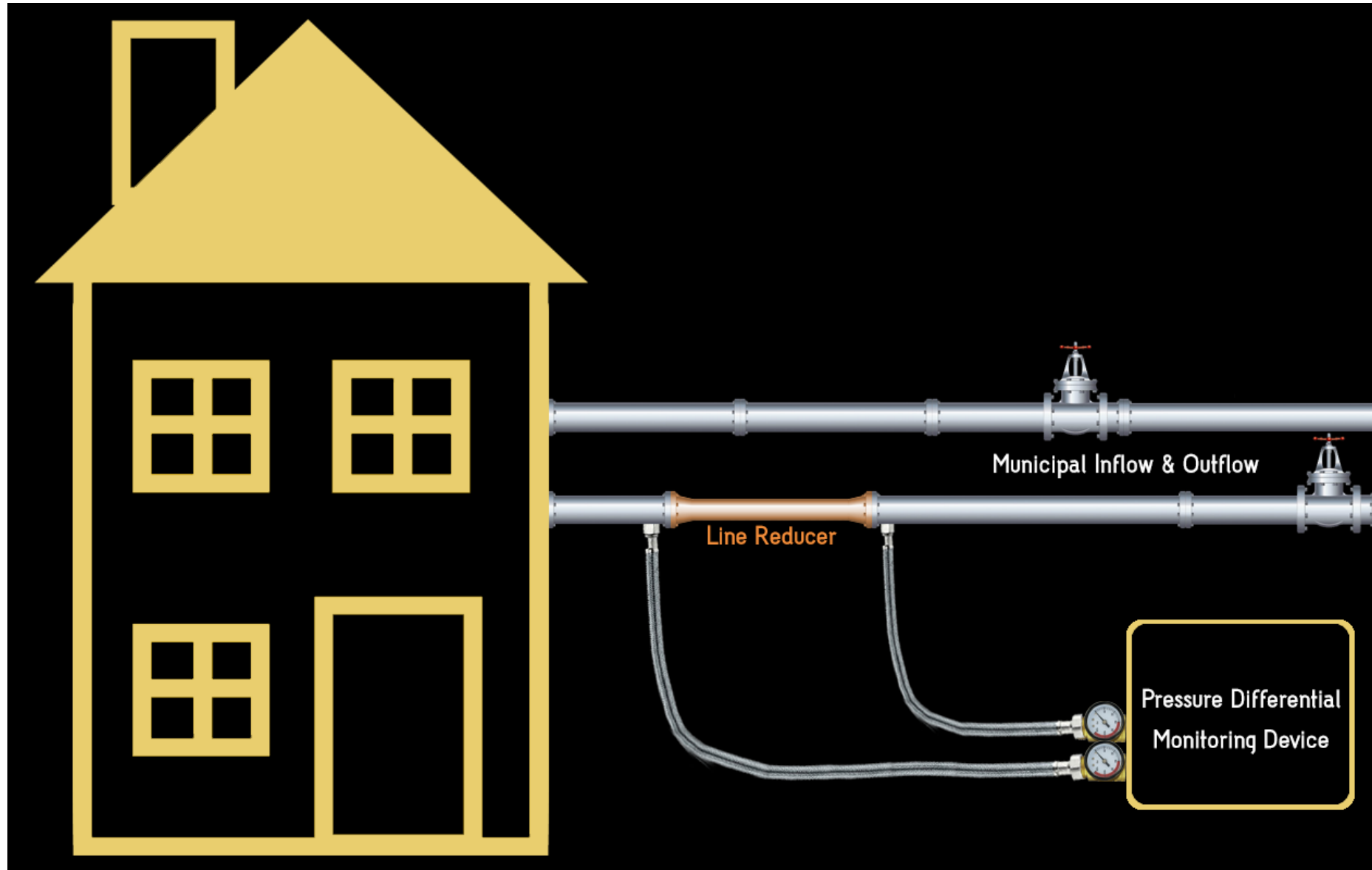

DIFFERENTIAL POWER ANALYSIS

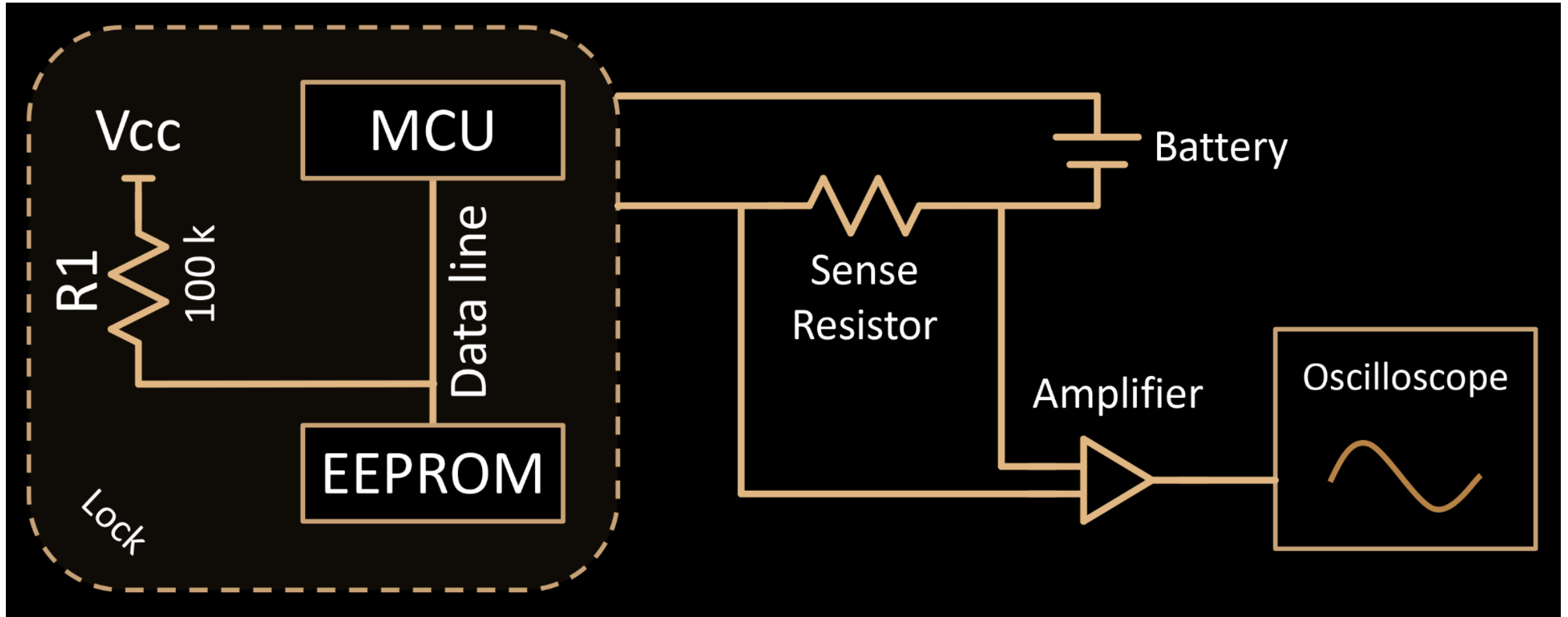

PLORE – “SIDE-CHANNEL ATTACKS ON HIGH-SECURITY ELECTRONIC SAFE LOCKS” [DEF CON 24]

DIFFERENTIAL POWER ANALYSIS

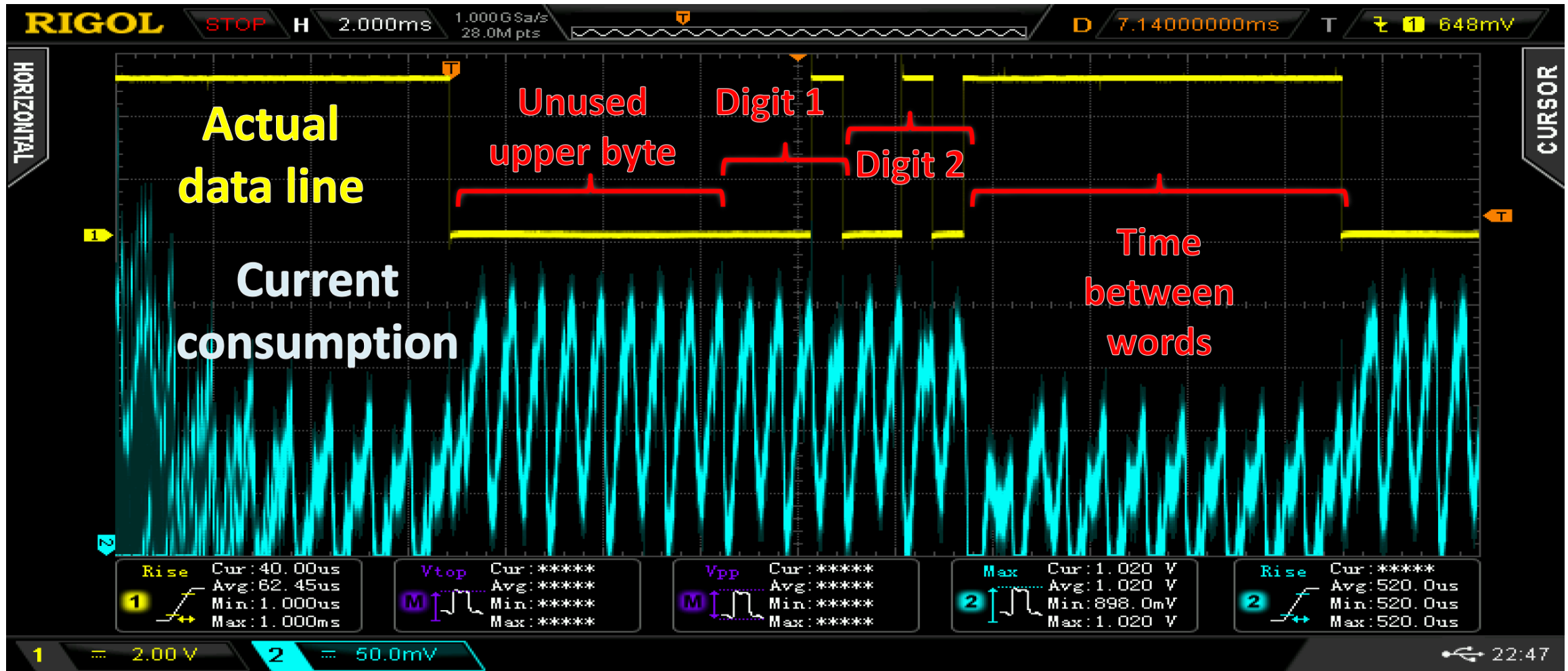

PLORE – “SIDE-CHANNEL ATTACKS ON HIGH-SECURITY ELECTRONIC SAFE LOCKS” [DEF CON 24]

DIFFERENTIAL POWER ANALYSIS

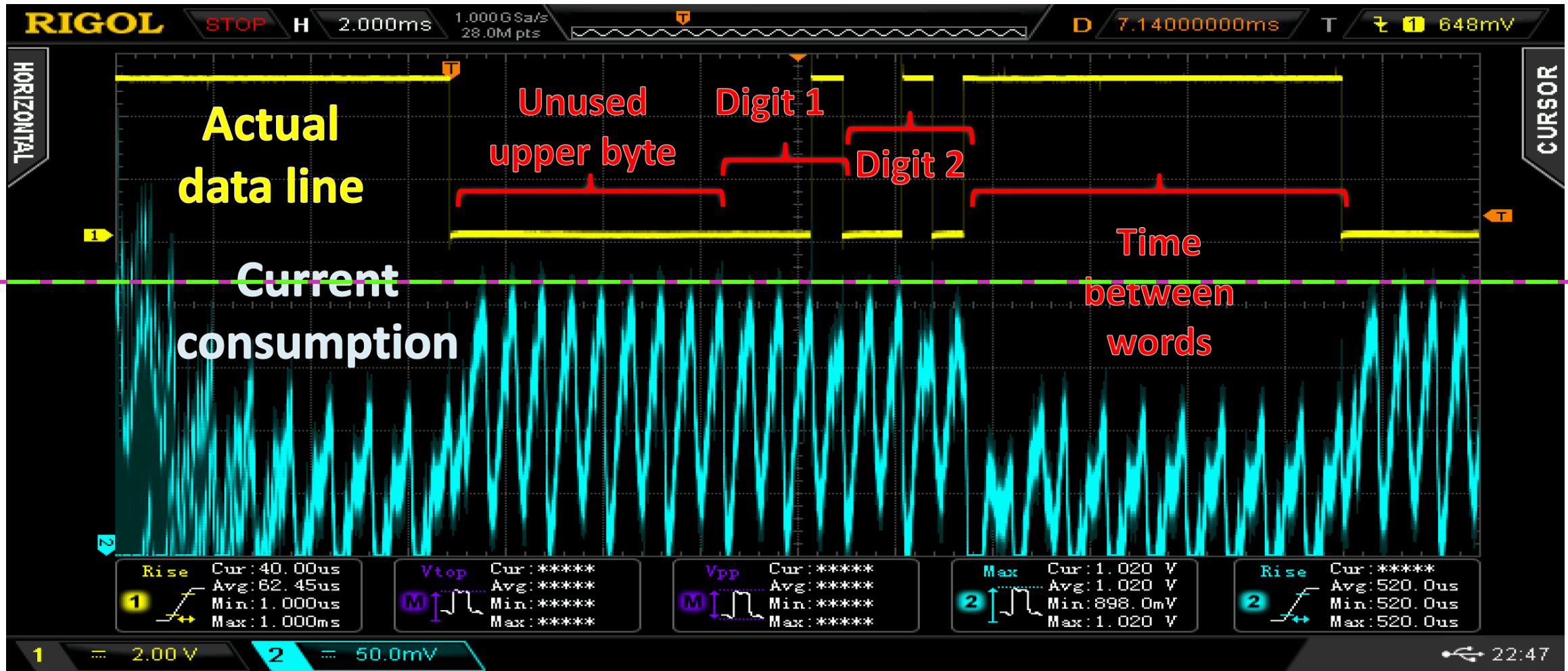

PLORE – “SIDE-CHANNEL ATTACKS ON HIGH-SECURITY ELECTRONIC SAFE LOCKS” [DEF CON 24]

DIFFERENTIAL POWER ANALYSIS

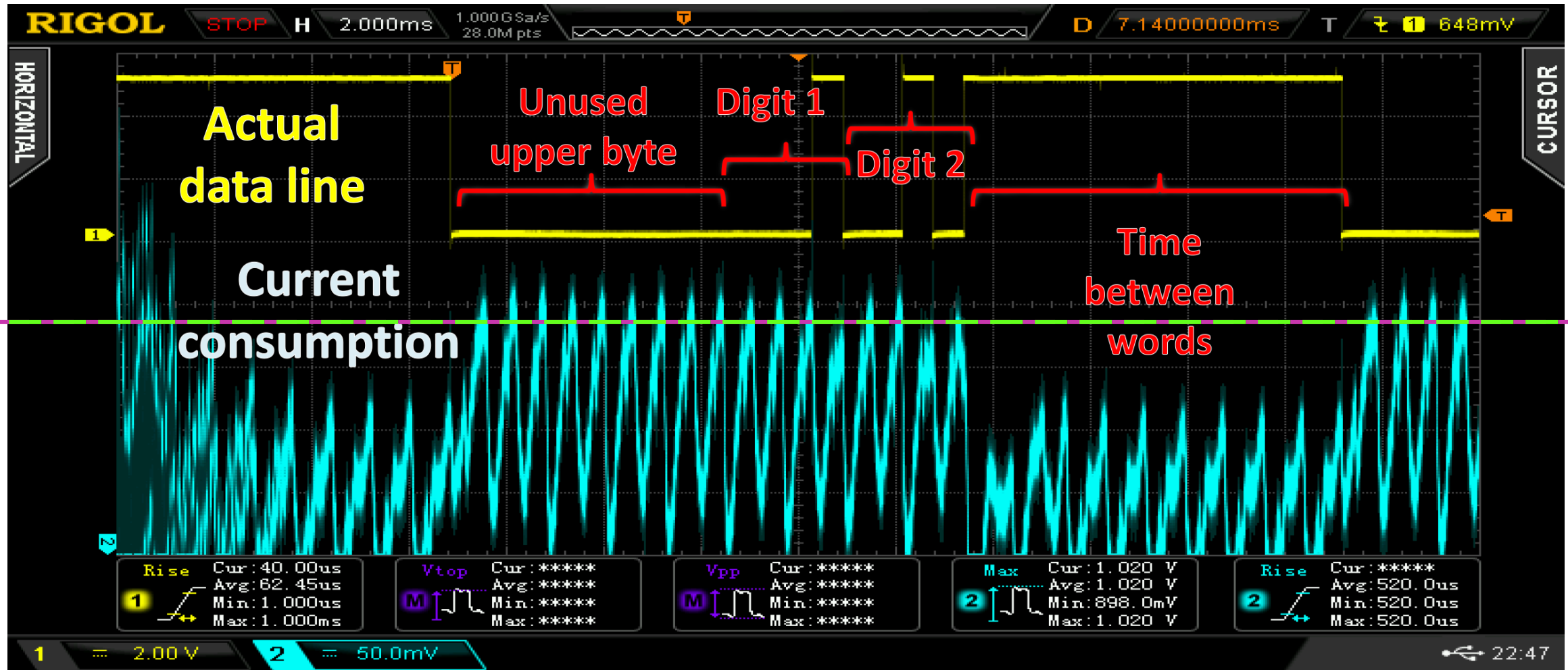

PLORE – “SIDE-CHANNEL ATTACKS ON HIGH-SECURITY ELECTRONIC SAFE LOCKS” [DEF CON 24]

DIFFERENTIAL POWER ANALYSIS



PLORE – “SIDE-CHANNEL ATTACKS ON HIGH-SECURITY ELECTRONIC SAFE LOCKS” [DEF CON 24]

DIFFERENTIAL POWER ANALYSIS

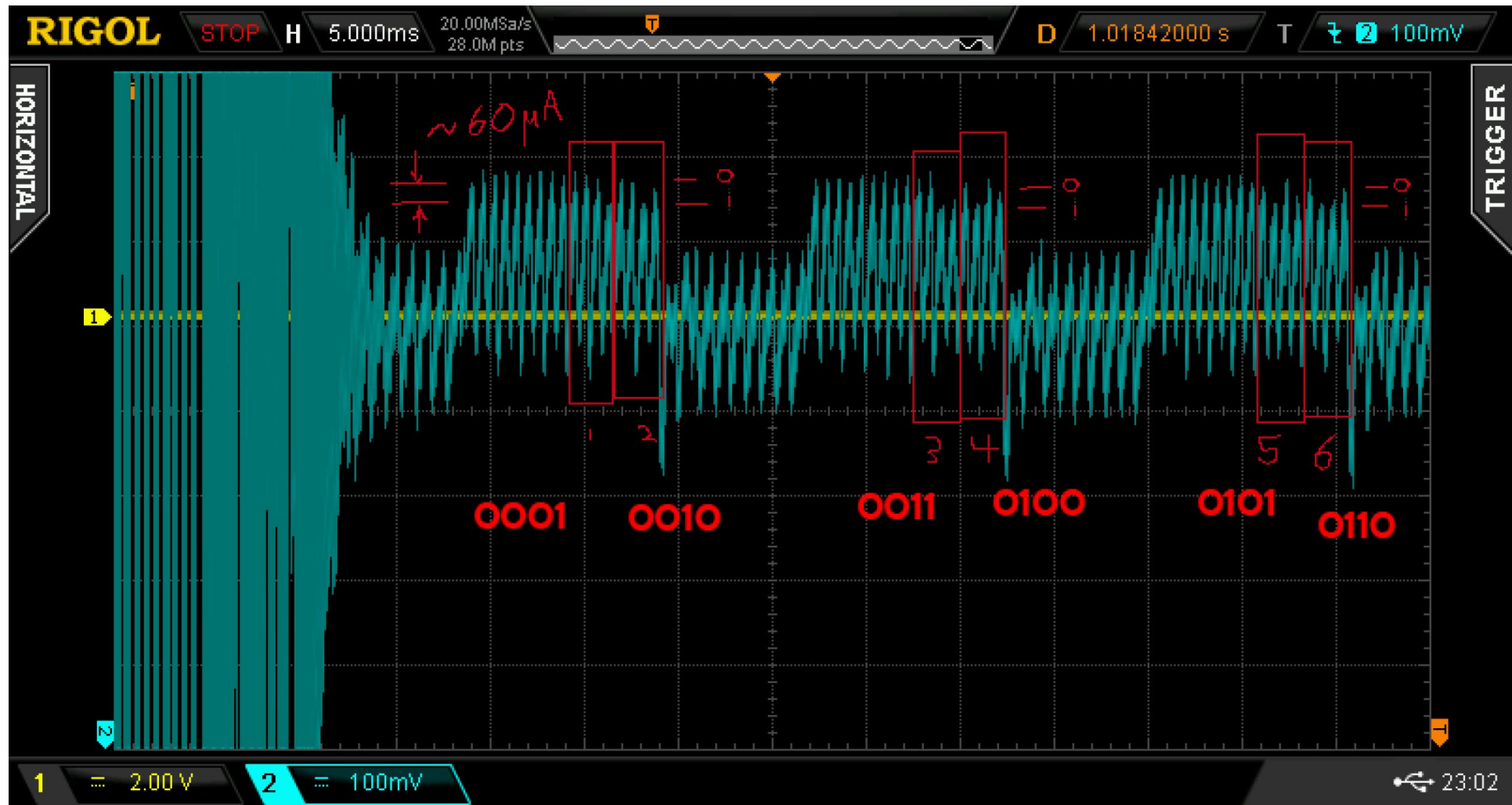

PLORE – “SIDE-CHANNEL ATTACKS ON HIGH-SECURITY ELECTRONIC SAFE LOCKS” [DEF CON 24]

DIFFERENTIAL POWER ANALYSIS

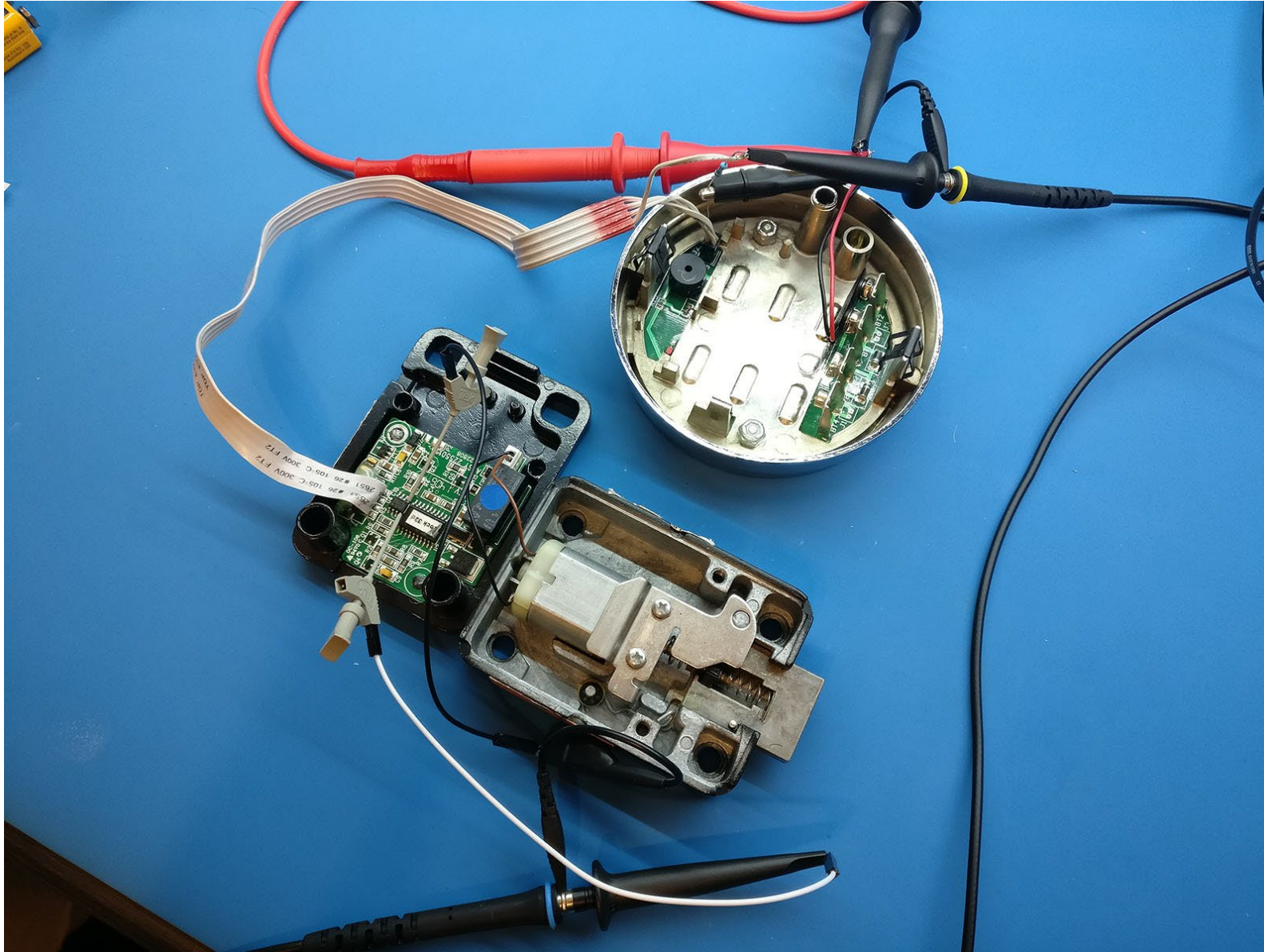

DIFFERENTIAL POWER ANALYSIS

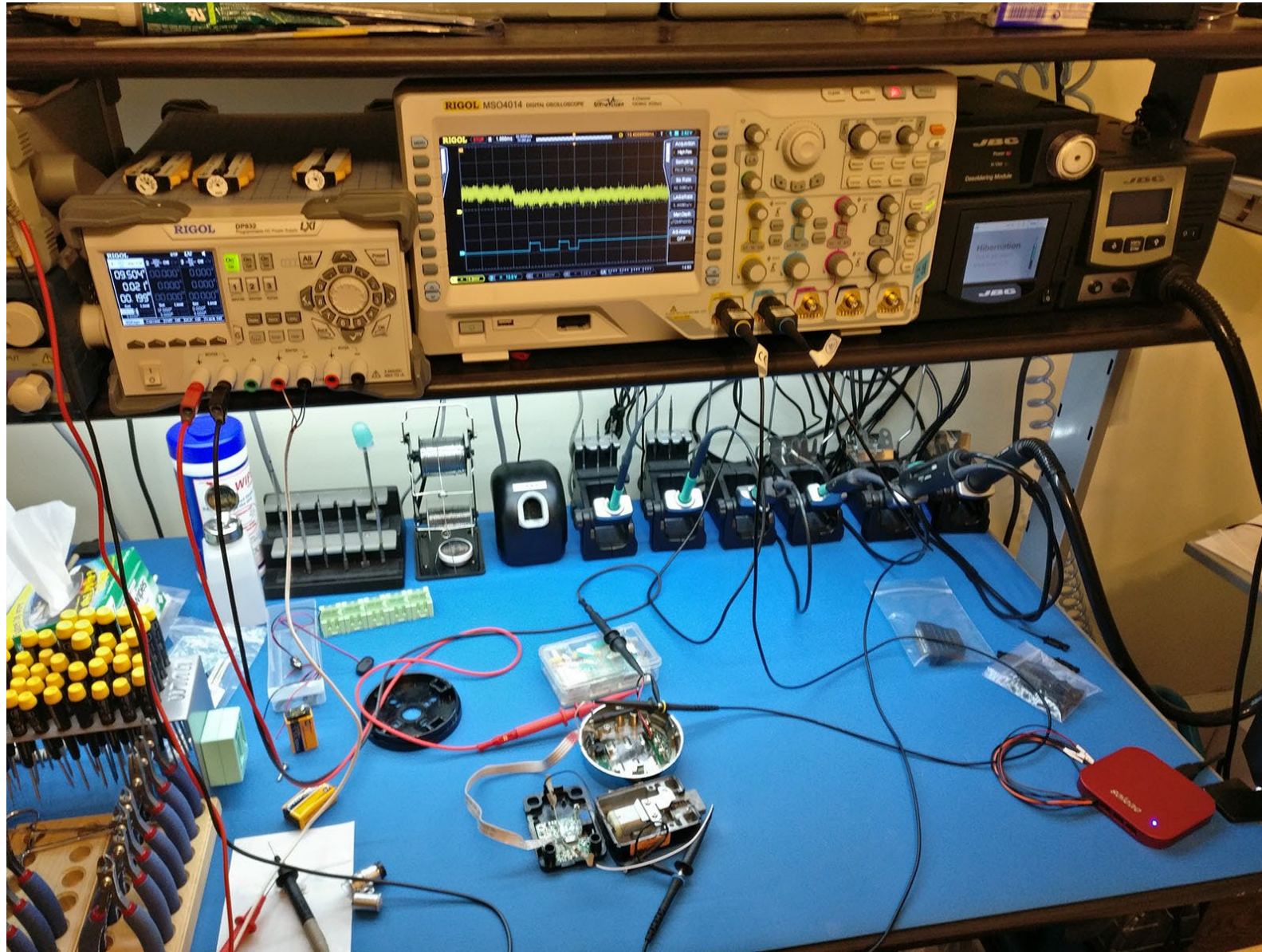

DIFFERENTIAL POWER ANALYSIS

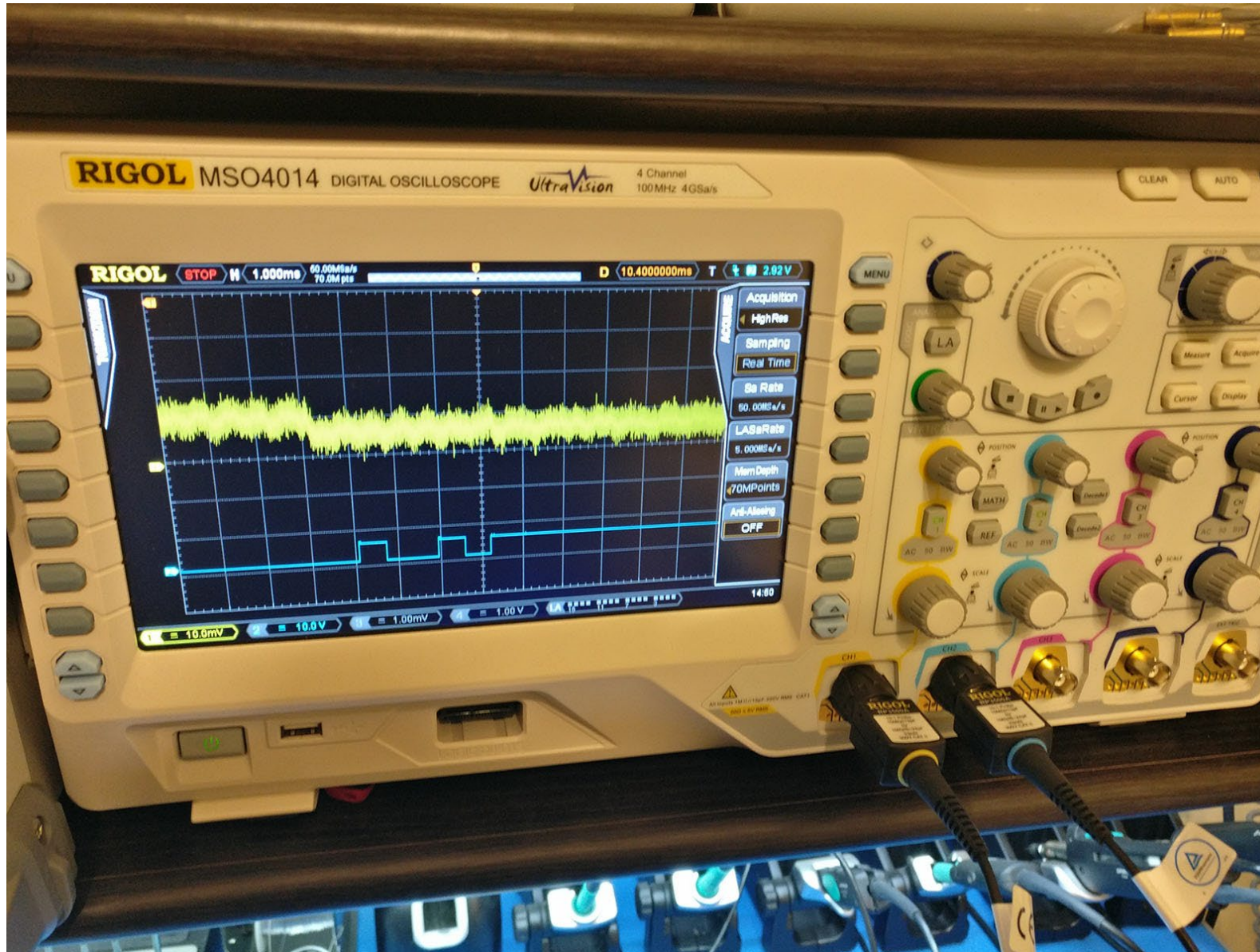

DIFFERENTIAL POWER ANALYSIS



DIFFERENTIAL POWER ANALYSIS

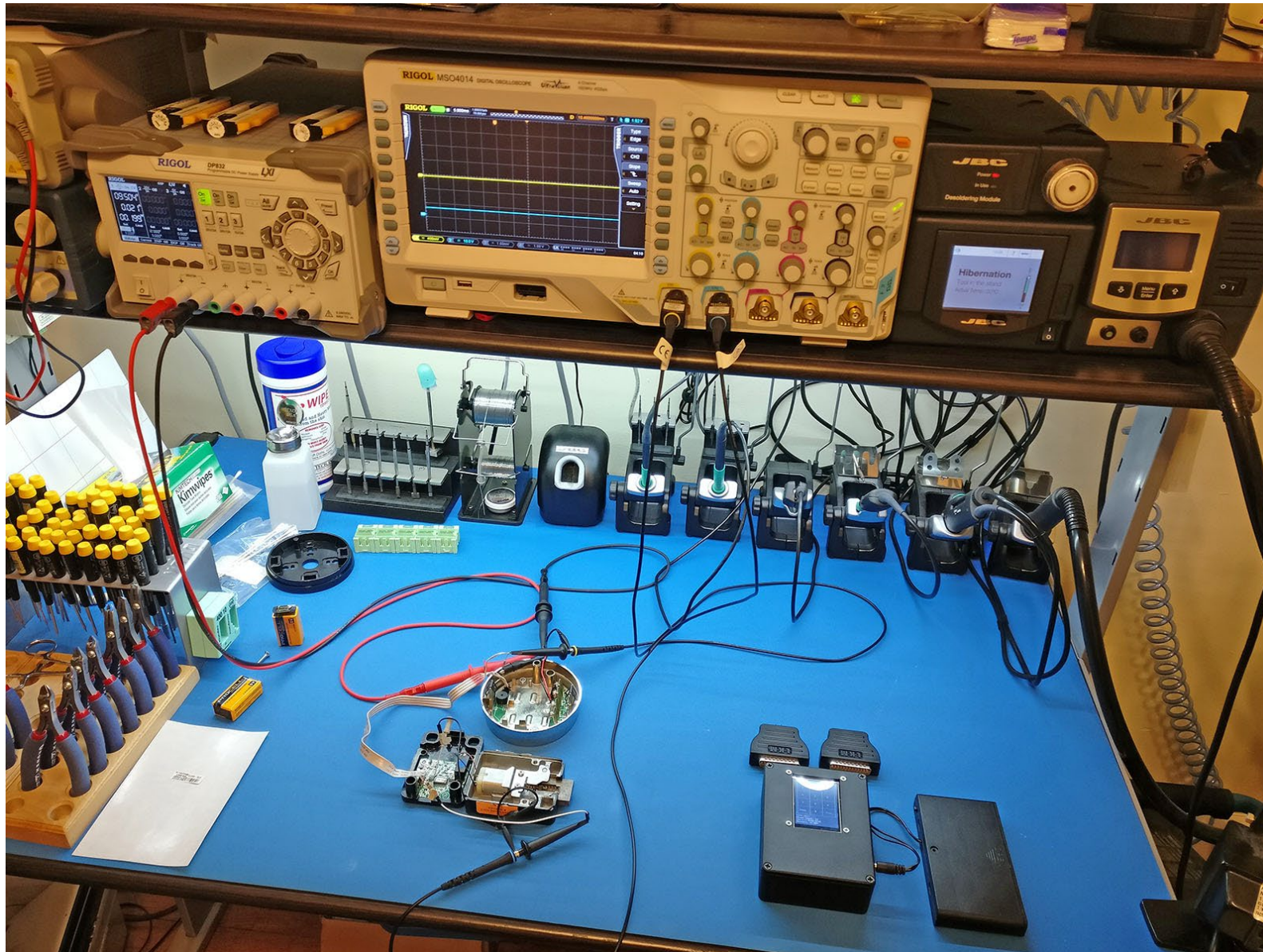

DIFFERENTIAL POWER ANALYSIS



DIFFERENTIAL POWER ANALYSIS



DIFFERENTIAL POWER ANALYSIS



So... SOME FOLK OPTED TO DITCH THE ELECTRONICS

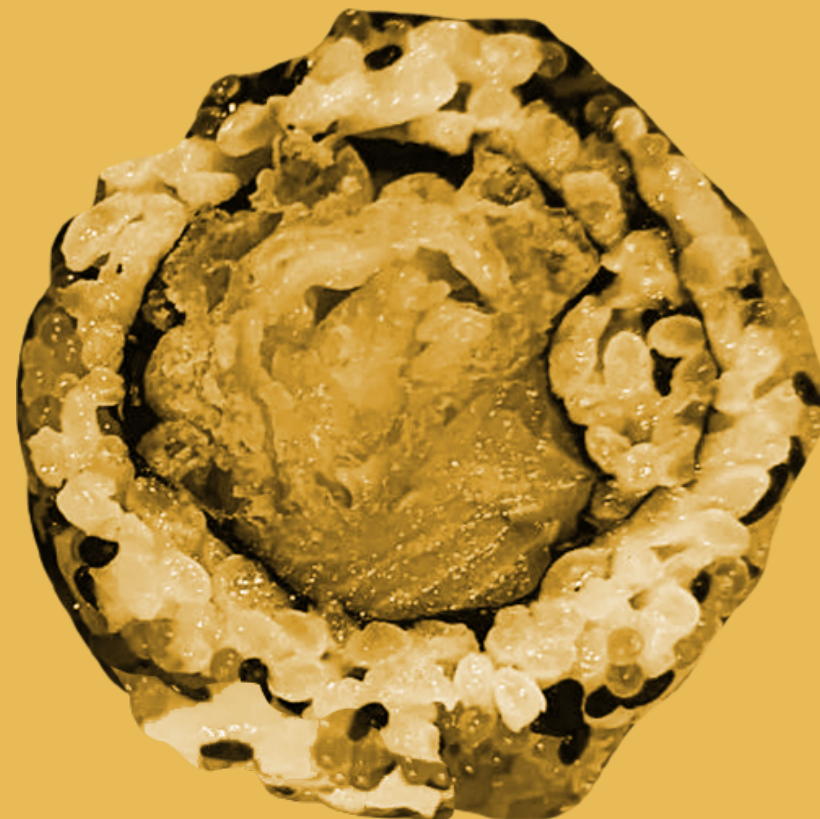

GOING BACK TO A MANUAL, MECHANICAL SAFE LOCK

Premium

Search



Gun Storage: The Good, The Bad, and The Ugly of Gun Safes and Locks



DeviantOllam
150K subscribers

Analytics

Edit video

DOWNLOAD AS: ▼

3.1K



Share

Promote

Download

Clip



69K views 2 years ago

I've had this talk slow cooking for a while now, in the form of notes, photos, advice, and elements of much older presentations I gave in the past. When the Liberal Gun Club (an org whom I strongly recommend people check out, link below!) asked me to present for their Distance Learning Series, that was the inspiration I needed to put this all together into a proper educational lecture. ...more

537 Comments

Sort by



Add a comment...

All From DeviantOllam Safe Locks



Lawyer. Passport. Locksmith. Gun. (A Talk About Risk &...
DeviantOllam
124K views · 1 year ago



TSA Keeps Breaking Into Gun Cases (And Now My Accounts...
DeviantOllam
395K views · 10 months ago



Step Out for RBL The Great Tommy Sleep Out "Challenge"
Challenger Troop CIC
40 views · 1 day ago
New



INCREDIBLE STORAGE SOLUTIONS YOU DIDN'T KNOW...
TechZone
3.1M views · 9 months ago



"Through the Eyes of a Thief" at DakotaCon 2023
DeviantOllam
103K views · 11 months ago



Opening Incredible Garage-Found Gun Safes After 8 Years...
Legacy Collectibles
1.6M views · 8 months ago



Top 10 Things NOT To Say In A Gun Store
Tundra Tactical
121K views · 7 months ago



Howard Payne & Deviant Ollam - This Key is Your Key, This Key ...
DeviantOllam
405K views · 7 years ago



Steelhead Fast-Access Pistol Box: Approved
Handgun Safe
6.4K views · 5 months ago



Liverstrong: A Presentation About Hacking Alcohol
DeviantOllam
22K views · 2 years ago

MECHANICAL SAFE LOCK RATINGS

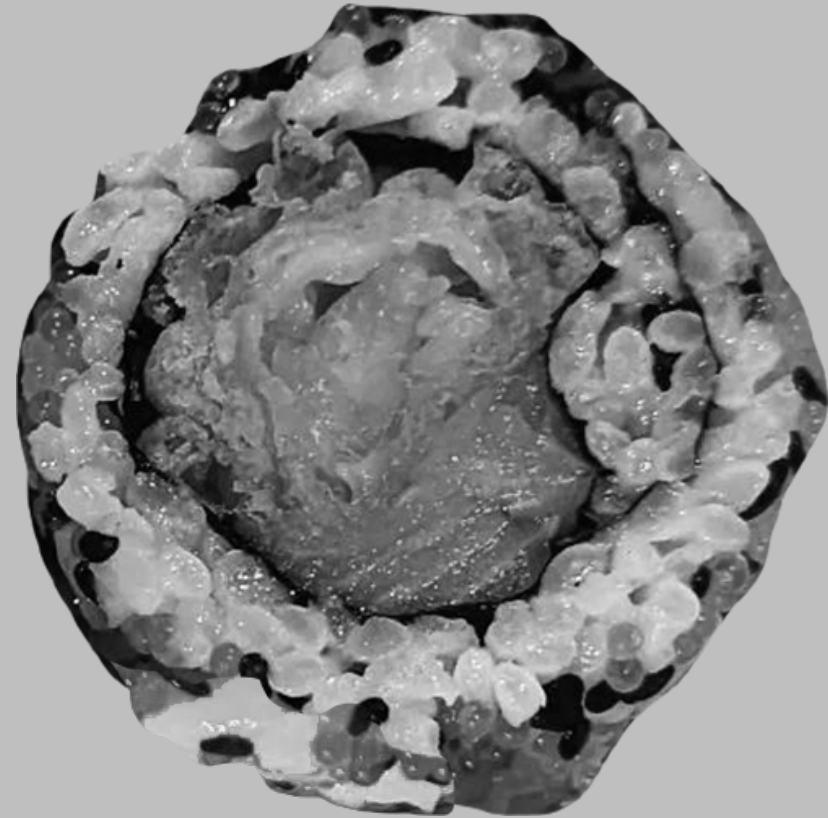

WHO OUTRANKS WHOM?



WHO OUTRANKS WHOM?



1ST LIEUTENANT

OUTRANKS



2ND LIEUTENANT

WHO OUTRANKS WHOM?



GROUP 1 SAFE LOCKS

ARE HIGHER RATED THAN



GROUP 2 SAFE LOCKS

SAFE LOCK RATINGS

	RESIST ATTACKER WHO IS	TIME NEEDED TO MANIPULATE	DIALING TOLERANCE
GROUP 1			
GROUP 2			

SAFE LOCK RATINGS

	RESIST ATTACKER WHO IS	TIME NEEDED TO MANIPULATE	DIALING TOLERANCE
GROUP 1	SKILLED		
GROUP 2	SEMI-SKILLED		

SAFE LOCK RATINGS

	RESIST ATTACKER WHO IS	TIME NEEDED TO MANIPULATE	DIALING TOLERANCE
GROUP 1	SKILLED	20 HOURS	
GROUP 2	SEMI-SKILLED	2 HOURS	

SAFE LOCK RATINGS

	RESIST ATTACKER WHO IS	TIME NEEDED TO MANIPULATE	DIALING TOLERANCE
GROUP 1	SKILLED	20 HOURS	±0.5 DIGIT
GROUP 2	SEMI-SKILLED	2 HOURS	±1.25 DIGITS

SAFE LOCK RATINGS



GROUP 1
S&G 2937



GROUP 2
S&G 6730

SAFE LOCK RATINGS

	RESIST ATTACKER WHO IS	TIME NEEDED TO MANIPULATE	DIALING TOLERANCE
GROUP 1	SKILLED	20 HOURS	±0.5 DIGIT
GROUP 2	SEMI-SKILLED	2 HOURS	±1.25 DIGITS

SAFE LOCK RATINGS

	RESIST ATTACKER WHO IS	TIME NEEDED TO MANIPULATE	DIALING TOLERANCE
GROUP 1	SKILLED	20 HOURS	±0.5 DIGIT
GROUP 2M	SKILLED	2 HOURS	±1.25 DIGITS
GROUP 2	SEMI-SKILLED	2 HOURS	±1.25 DIGITS

SAFE LOCK RATINGS



GROUP 2M
S&G 6630



GROUP 2
S&G 6730

SAFE LOCK RATINGS



They're the same picture.

SAFE LOCK RATINGS



GROUP 2M
S&G 6630



GROUP 2
S&G 6730

SAFE LOCK RATINGS

	RESIST ATTACKER WHO IS	TIME NEEDED TO MANIPULATE	DIALING TOLERANCE
GROUP 1	SKILLED	20 HOURS	±0.5 DIGIT
GROUP 2M	SKILLED	2 HOURS	±1.25 DIGITS
GROUP 2	SEMI-SKILLED	2 HOURS	±1.25 DIGITS

SAFE LOCK RATINGS

	RESIST ATTACKER WHO IS	TIME NEEDED TO MANIPULATE	DIALING TOLERANCE
GROUP 1R	SKILLED	20 HOURS	±0.5 DIGIT
GROUP 1	SKILLED	20 HOURS	±0.5 DIGIT
GROUP 2M	SKILLED	2 HOURS	±1.25 DIGITS
GROUP 2	SEMI-SKILLED	2 HOURS	±1.25 DIGITS

RADIOGRAPHIC ATTACK



ANTI-RADIOGRAPHIC SAFE LOCKS



GROUP 1R
(S&G 8430)

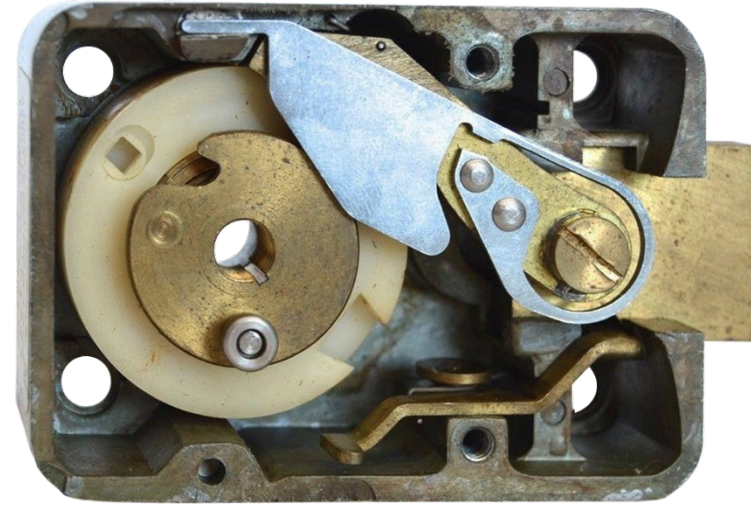

GROUP 1R
(S&G 8560)

ANTI-RADIOGRAPHIC SAFE LOCKS



CURRENT US ARMORY STANDARD



SARGENT & GREENLEAF 2937

MECHANICAL SAFE LOCKS ARE STILL ON THE MARKET

Lockmasters Sells Only to Security Professionals

800-654-0637

Wishlist (0)

SHOPPING CART (0)

LOCKMASTERS

Search



Search by Car



Technician Search

Education

Browse by:

Products

Manufacturers

Sale

Go to:

SALE

Access Control

Automotive Tools

Cam & Padlocks

Door Hardware, Cylinders & Cores

Government Hardware & Tools

Locksmith Tools and Supplies

Safe Locks and Tools

Safes

Home / Safe Locks and Tools / Mechanical Safe Locks / S&G 6700 Series Mechanical Safe Lock Package - Front Reading Dial; Model 6730



Description

Technical Specs

Resources

Video

SG6730ADJS

Manufacturer: Sargent & Greenleaf 3 Wheel, Front Reading Dial Lock Body

Dial Ring with Black/White Finish

U.L. Group 2

Sargent and Greenleaf

S&G 6700 Series Mechanical Safe Lock Package - Front Reading Dial; Model 6730

Details

Availability: 668 in stock

SKU: **SG6730ADJS**

Old price: \$89.07

List Price: \$158.64

Your Price: \$72.50

Warehouse	Stock qty
KY	624
DC	44

Order

- 1 +

Add to cart

Buy Now

Features

MECHANICAL SAFE LOCKS ARE STILL ON THE MARKET

Lockmasters Sells Only to Security Professionals

800-654-0637

Wishlist (0)

SHOPPING CART (0)

LOCKMASTERS

Search



Search by Car



Technician Search

Education

Browse by:

Products

Manufacturers

Sale

Go to:

SALE

Access Control

Automotive Tools

Cam & Padlocks

Door Hardware, Cylinders & Cores

Government Hardware & Tools

Locksmith Tools and Supplies

Safe Locks and Tools

Safes

Home / Safe Locks and Tools / Mechanical Safe Locks / **S&G 6630 Series Mechanical Safe Lock Package with Top Reading, Black & White Dial and Ring**



Sargent and Greenleaf

S&G 6630 Series Mechanical Safe Lock Package With Top Reading, Black & White Dial And Ring

Details

Availability: 5 in stock

SKU: **SG6630ADJ**

Your Price: \$153.83

Warehouse	Stock qty
KY	5
DC	0

Order

- 1 +

Add to cart

Buy Now

Features

Description

Technical Specs

Resources

Video

SG6630ADJ

Manufacturer: Sargent & Greenleaf

Product Description: S&G 3-Wheel Lock Package: Group 2M

Includes D225 Black and White Top-Reading, Key-Locking Dial and R167 Dial Ring

MECHANICAL SAFE LOCKS ARE STILL ON THE MARKET

Lockmasters Sells Only to Security Professionals

800-654-0637

Wishlist (0)

SHOPPING CART (0)

LOCKMASTERS

Search



Search by Car



Technician Search

Education

Browse by:

Products

Manufacturers

Sale

Go to:

SALE

Access Control

Automotive Tools

Cam & Padlocks

Door Hardware, Cylinders & Cores

Government Hardware & Tools

Locksmith Tools and Supplies

Safe Locks and Tools

Safes

Home / Safe Locks and Tools / Mechanical Safe Locks / **S&G 8550 Series Group 1 Mechanical Safe Lock Package**



Sargent and Greenleaf

S&G 8550 Series Group 1 Mechanical Safe Lock Package

Details

Availability: 31 in stock

SKU: **SG8550ADJ**

List Price: \$413.24

Your Price: \$238.80

Warehouse	Stock qty
KY	28
DC	3

Order

- 1 +

Add to cart

Buy Now

Features

♥ Add to wishlist

Description

Technical Specs

Resources

Video

SG8550ADJ

Manufacturer: Sargent & Greenleaf

Product Description: 8550 Series Mechanical Safe Lock Package

Series: 8550 UL Group 1

MECHANICAL SAFE LOCKS ARE STILL ON THE MARKET

Lockmasters Sells Only to Security Professionals

800-654-0637

Wishlist (0)

SHOPPING CART (0)

LOCKMASTERS

Search



Search by Car



Technician Search

Education

Browse by:

Products

Manufacturers

Sale

Go to:

SALE

Access Control

Automotive Tools

Cam & Padlocks

Door Hardware, Cylinders & Cores

Government Hardware & Tools

Locksmith Tools and Supplies

Safe Locks and Tools

Safes

Home / Safe Locks and Tools / Mechanical Safe Locks / **S&G 8560 Series Mechanical Safe Lock Package**



Description

Technical Specs

Resources

Video

SG8560ADJ

S&G Group1R lock with Spy-proof black & white dial and ring

Sargent and Greenleaf

S&G 8560 Series Mechanical Safe Lock Package

Details

Availability: 21 in stock

SKU: **SG8560ADJ**

List Price: \$456.84

Your Price: \$271.23

Warehouse	Stock qty
KY	17
DC	4

Order

- 1 +

Add to cart

Buy Now

Features

♥ Add to wishlist

MECHANICAL SAFE LOCKS ARE STILL ON THE MARKET

Lockmasters Sells Only to Security Professionals

800-654-0637

Wishlist (0)

SHOPPING CART (0)

LOCKMASTERS

Search



Search by Car



Technician Search

Education

Browse by:

Products

Manufacturers

Sale

Go to:

SALE

Access Control

Automotive Tools

Cam & Padlocks

Door Hardware, Cylinders & Cores

Government Hardware & Tools

Locksmith Tools and Supplies

Safe Locks and Tools

Safes

Home / Safe Locks and Tools / Mechanical Safe Locks / S&G 2937 Lock Series - Group 1 with Dial and Ring



Description

Technical Specs

Resources

Video

SG2937200

Manufacturer: Sargent & Greenleaf

Product Description: S&G 3-Wheel Mechanical Safe Lock Kit
With Lock, Dial, Ring and Lockbolt

Sargent and Greenleaf

S&G 2937 Lock Series - Group 1 With Dial And Ring

Details

Availability: 71 in stock

SKU: **SG2937200**

List Price: \$804.46

Your Price: \$458.97

Warehouse	Stock qty
KY	39
DC	32

Order

- 1 +

Add to cart

Buy Now

Features

♥ Add to wishlist

SWAPPING OUT AN ELECTRONIC SAFE LOCK

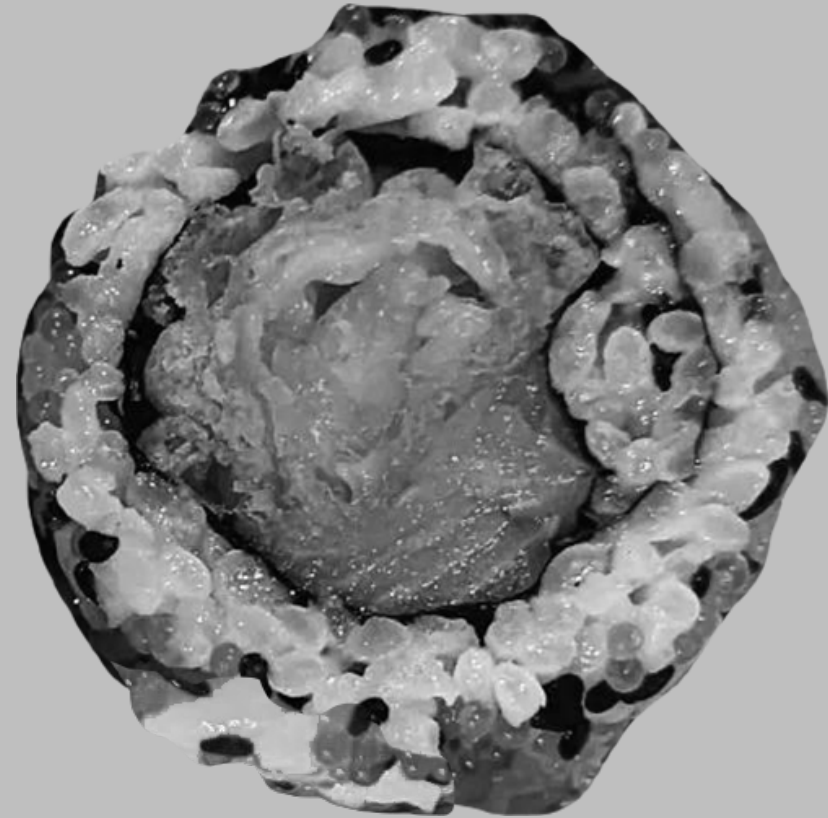

SWAPPING OUT AN ELECTRONIC SAFE LOCK



SWAPPING OUT AN ELECTRONIC SAFE LOCK

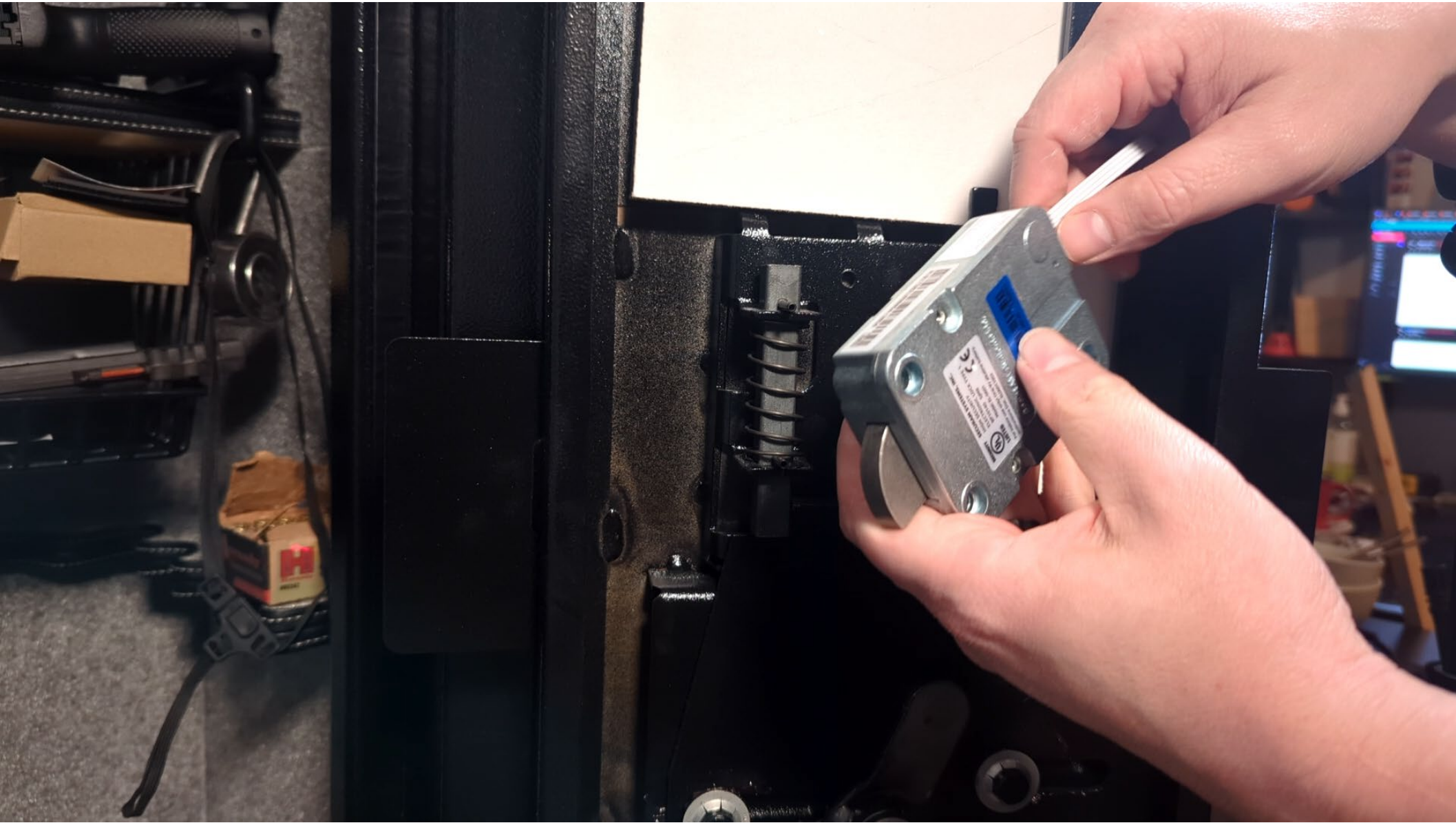

SWAPPING OUT AN ELECTRONIC SAFE LOCK



SWAPPING OUT AN ELECTRONIC SAFE LOCK



SWAPPING OUT AN ELECTRONIC SAFE LOCK



SWAPPING OUT AN ELECTRONIC SAFE LOCK



SWAPPING OUT AN ELECTRONIC SAFE LOCK



MECHANICAL LOCKS AREN'T IMPENETRABLE

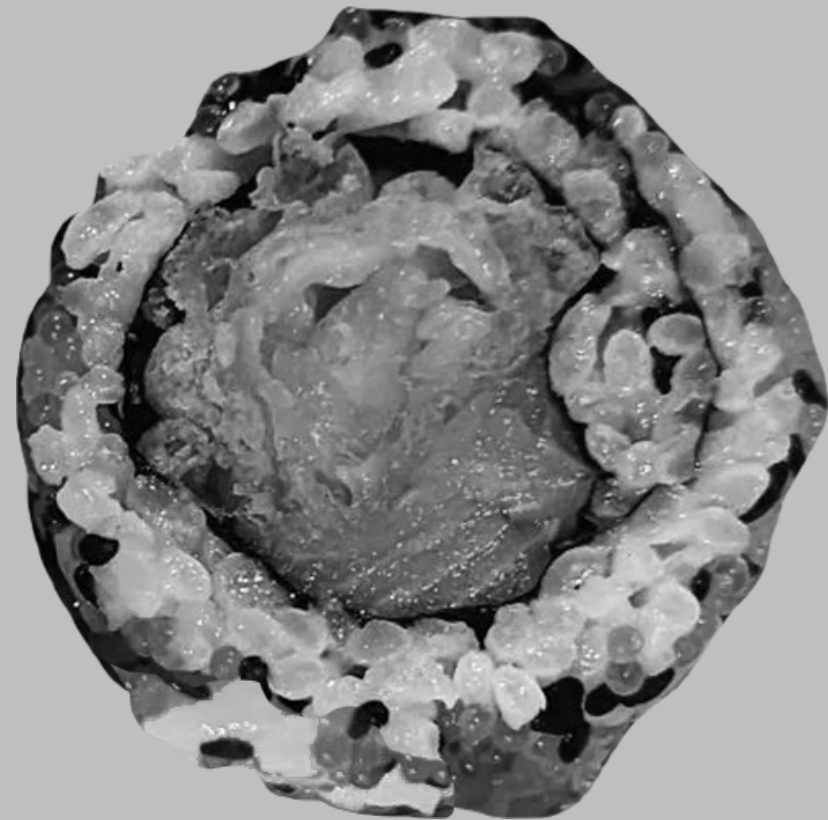

TARGETED APPLICATION OF TOOLS AND EFFORT



ROLLING RIGHT ALONG...

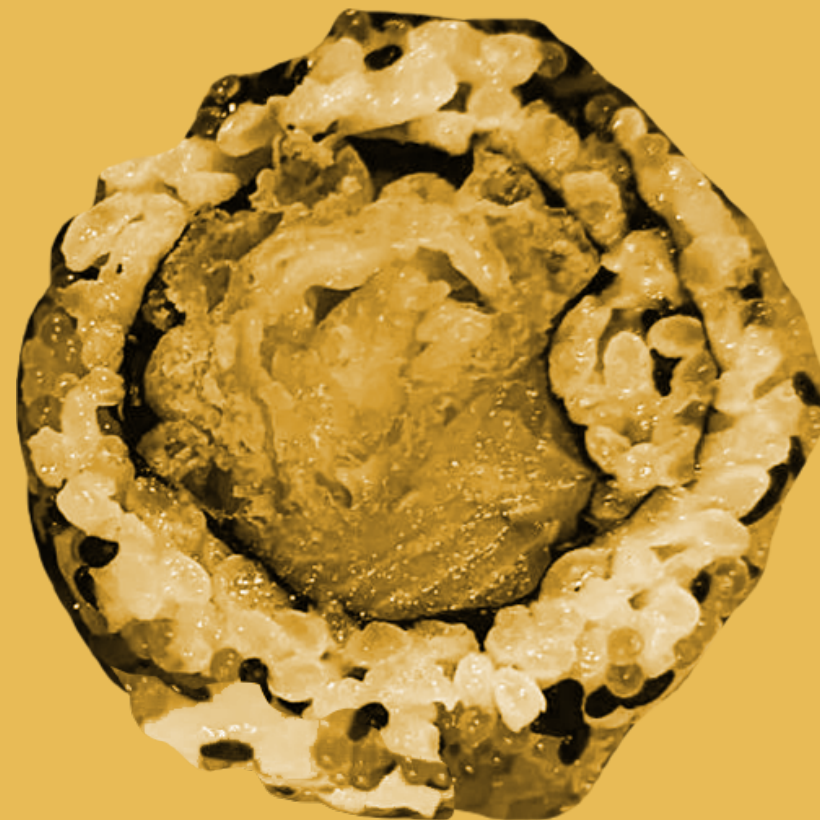

COOKING AND BAKING IS FUN

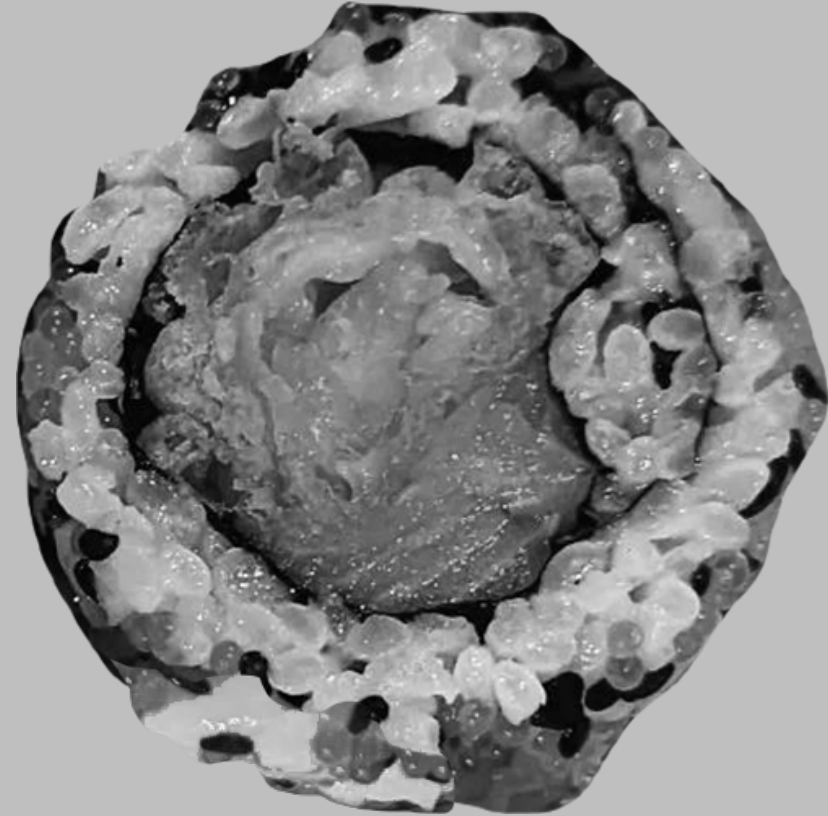

TARAH AND I LIKE TO MAKE FOOD



TARAH AND I LIKE TO MAKE FOOD



TARAH AND I LIKE TO MAKE FOOD



TARAH AND I LIKE TO MAKE FOOD

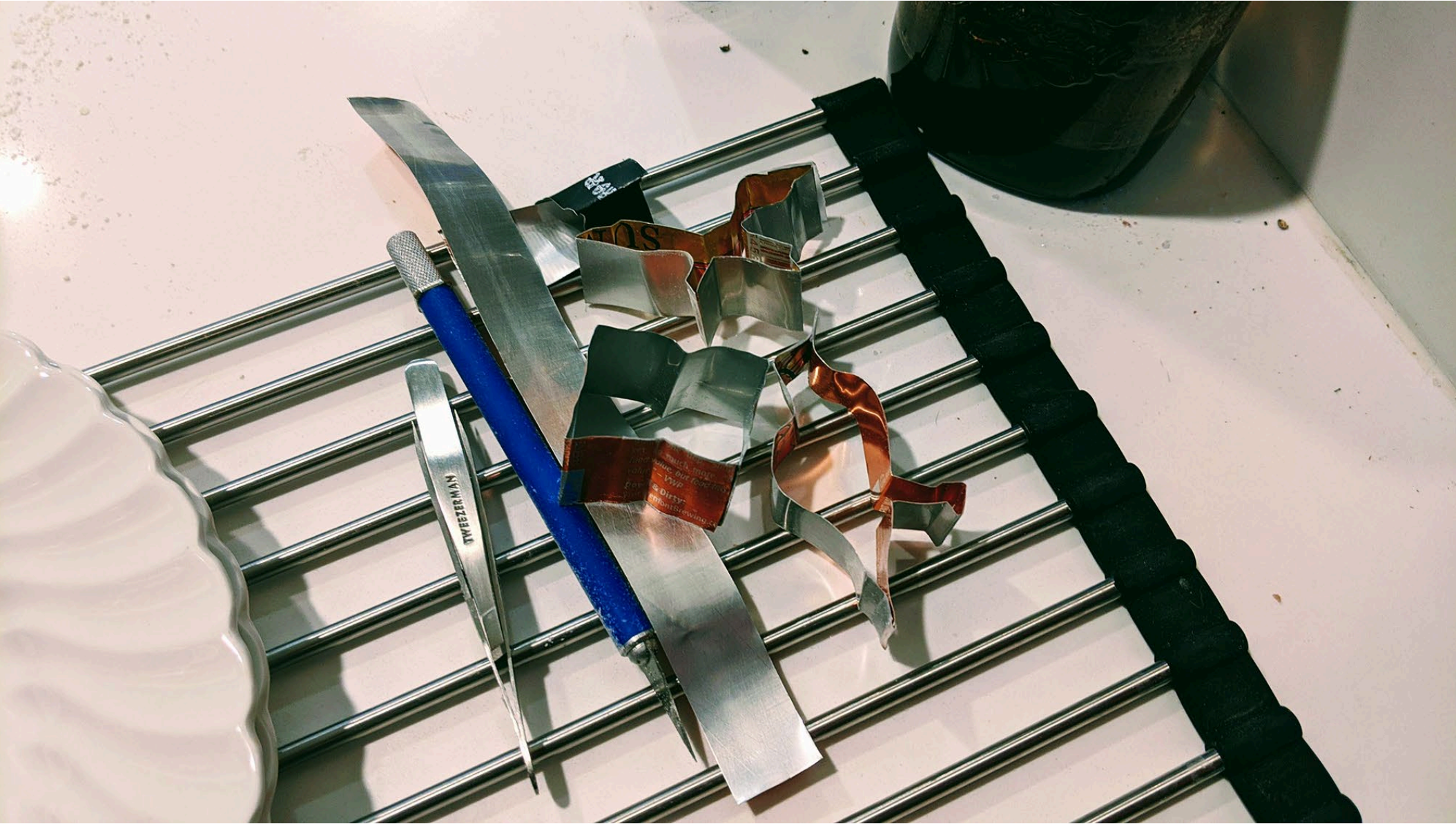

TARAH AND I LIKE TO MAKE FOOD



TARAH AND I LIKE TO MAKE FOOD



TARAH AND I LIKE TO MAKE FOOD



TARAH AND I LIKE TO MAKE FOOD



TARAH AND I LIKE TO MAKE FOOD



TARAH AND I LIKE TO MAKE FOOD



TARAH AND I LIKE TO MAKE FOOD



TARAH AND I LIKE TO MAKE FOOD



TARAH AND I LIKE TO MAKE FOOD



TARAH AND I LIKE TO MAKE FOOD



TARAH AND I LIKE TO MAKE FOOD



TARAH AND I LIKE TO MAKE FOOD



TARAH AND I LIKE TO MAKE FOOD



TARAH AND I LIKE TO MAKE FOOD



TARAH AND I LIKE TO MAKE FOOD



TARAH AND I LIKE TO MAKE FOOD



TARAH AND I LIKE TO MAKE FOOD



TARAH AND I LIKE TO PRODUCE OUR OWN FOOD



TARAH AND I LIKE TO PRODUCE OUR OWN FOOD



I WANTED TO BUILD SKILLS AND DO MORE



I WANTED TO BUILD SKILLS AND DO MORE



I WANTED TO BUILD SKILLS AND DO MORE



I WANTED TO BUILD SKILLS AND DO MORE



FOOD IS AWESOME



SHARING HOUSEHOLD DUTIES

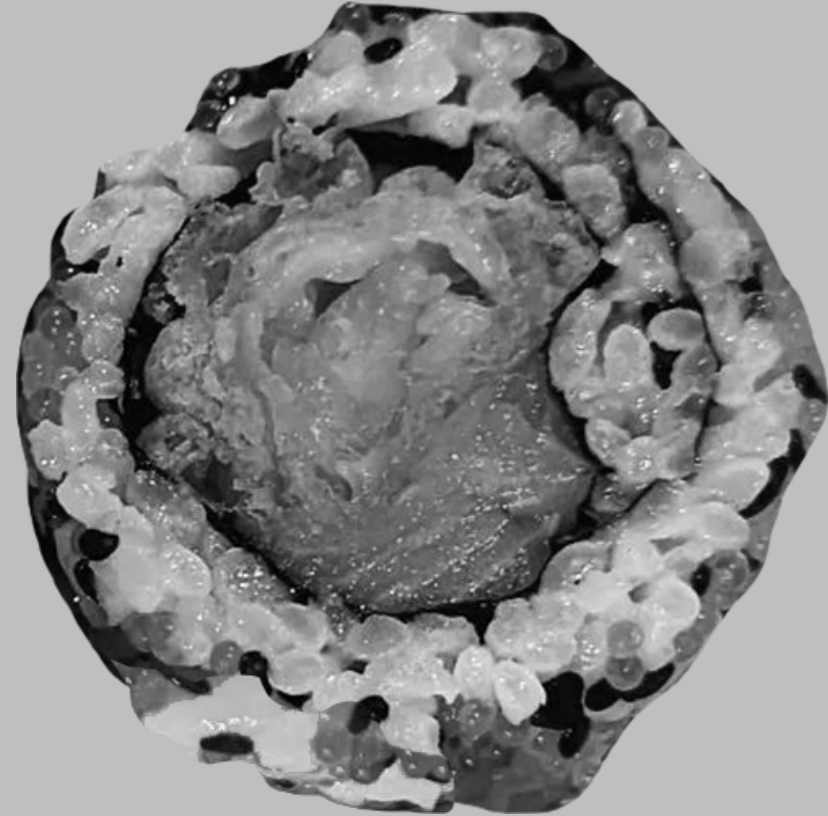

SHARING THE COOKING



JAPANESE FOOD



JAPANESE FOOD

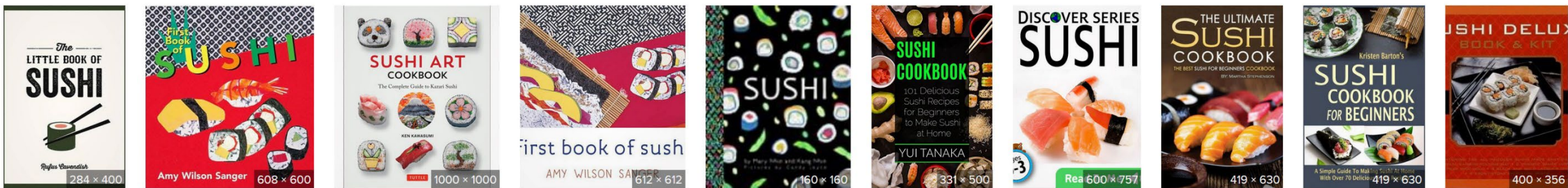

THURSDAY NIGHT SUSHI



THURSDAY NIGHT SUSHI



THURSDAY NIGHT SUSHI



THURSDAY NIGHT SUSHI



THURSDAY NIGHT SUSHI



THURSDAY NIGHT SUSHI



THURSDAY NIGHT SUSHI



THURSDAY NIGHT SUSHI



THURSDAY NIGHT SUSHI



THURSDAY NIGHT SUSHI



THURSDAY NIGHT SUSHI



THURSDAY NIGHT SUSHI



THURSDAY NIGHT SUSHI



THURSDAY NIGHT SUSHI



THURSDAY NIGHT SUSHI



THURSDAY NIGHT SUSHI



THURSDAY NIGHT SUSHI



THURSDAY NIGHT SUSHI



THURSDAY NIGHT SUSHI



THURSDAY NIGHT SUSHI



THURSDAY NIGHT SUSHI



THURSDAY NIGHT SUSHI



THURSDAY NIGHT SUSHI



THURSDAY NIGHT SUSHI



MYTHS AND MISCONCEPTIONS

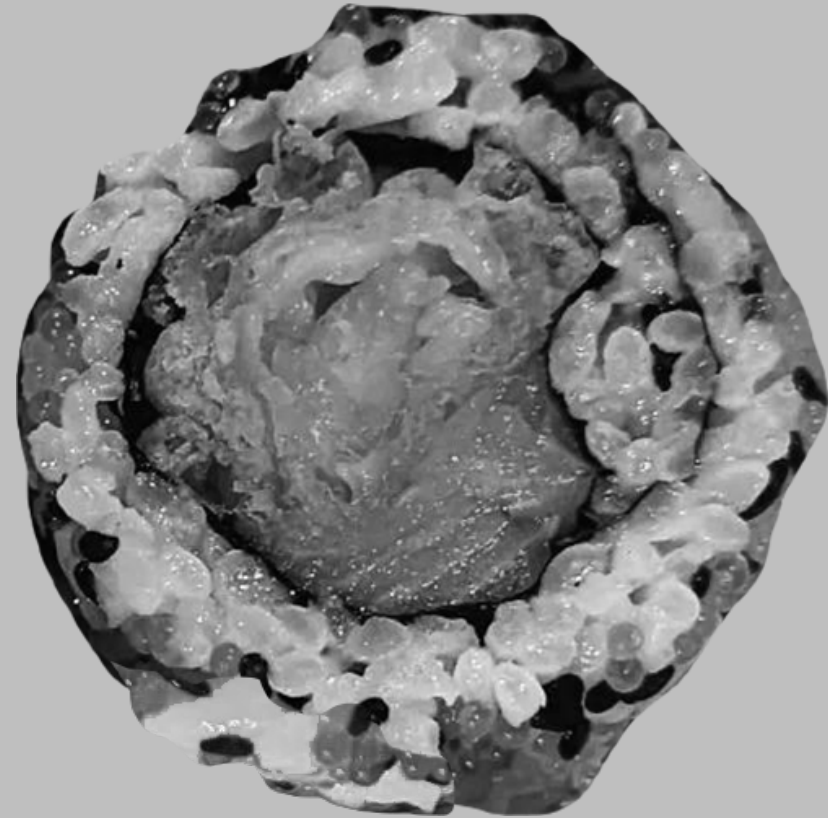

“SUSHI IS ALWAYS RAW”



“SUSHI IS HIGH CARB”



“SUSHI CAN’T BE VEGAN”



“SUSHI CAN’T BE VEGAN”



“SUSHI CAN’T BE VEGAN”



“SUSHI CAN'T BE VEGAN”



“SUSHI IS EXPENSIVE”



“SUSHI IS EXPENSIVE”

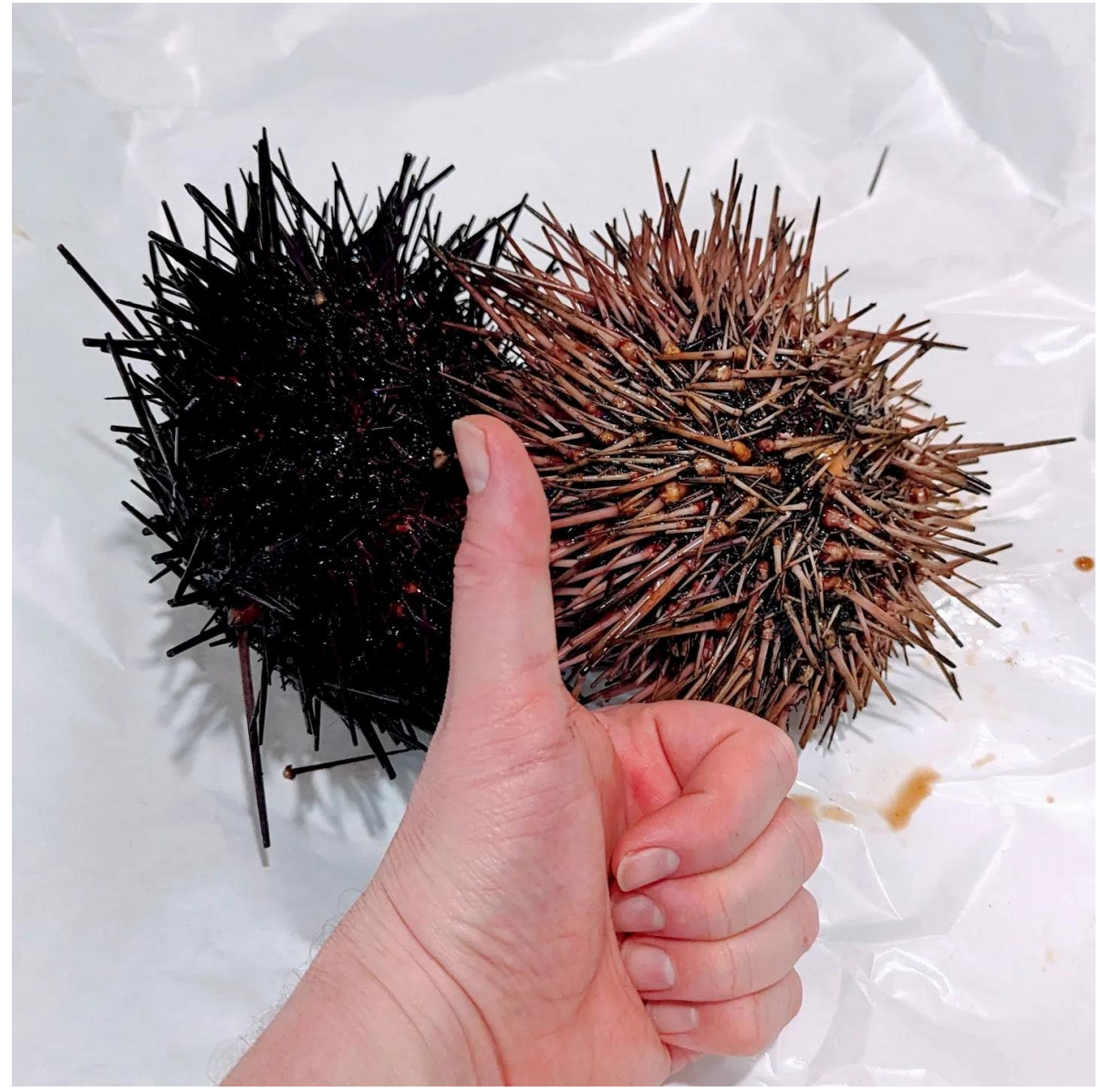

“SUSHI IS EXPENSIVE”



“SUSHI IS EXPENSIVE”



“MAKING SUSHI IS CHALLENGING”



“MAKING SUSHI IS CHALLENGING”



“MAKING SUSHI IS CHALLENGING”



“MAKING SUSHI IS CHALLENGING”



I AM AN IDIOT... AND SO CAN YOU



SUPPLIES YOU MAY WANT TO HAVE

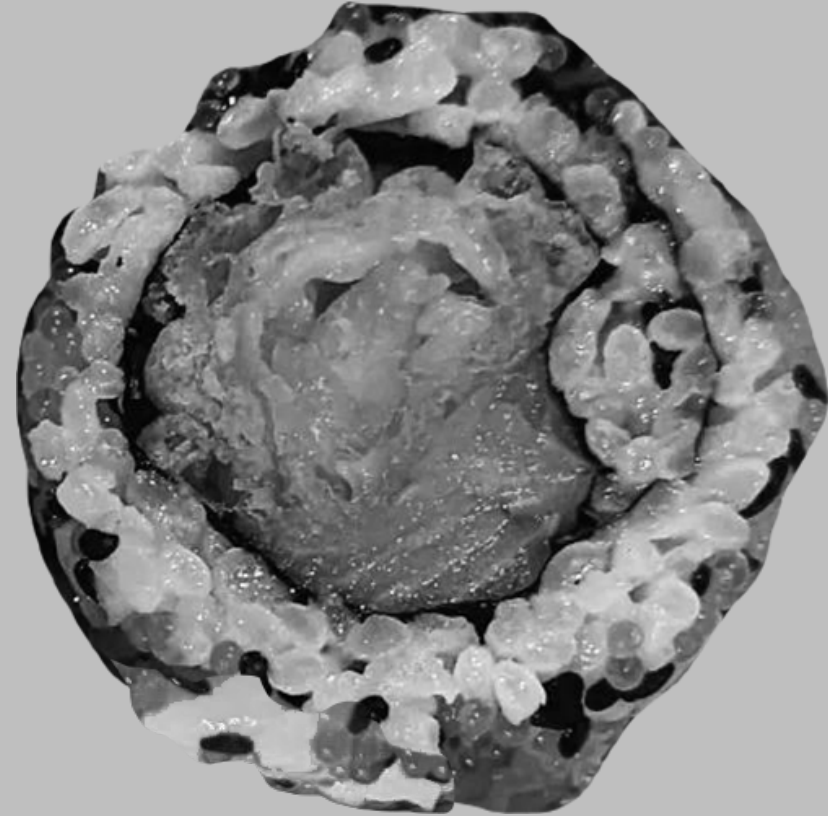

SUSHI SUPPLIES

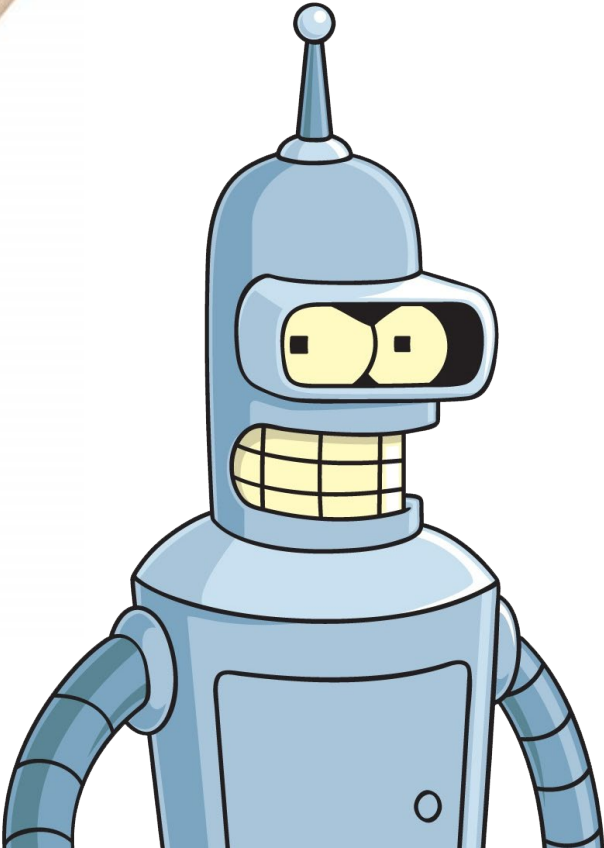

SUSHI MAKING HOW-TO AND TIPS

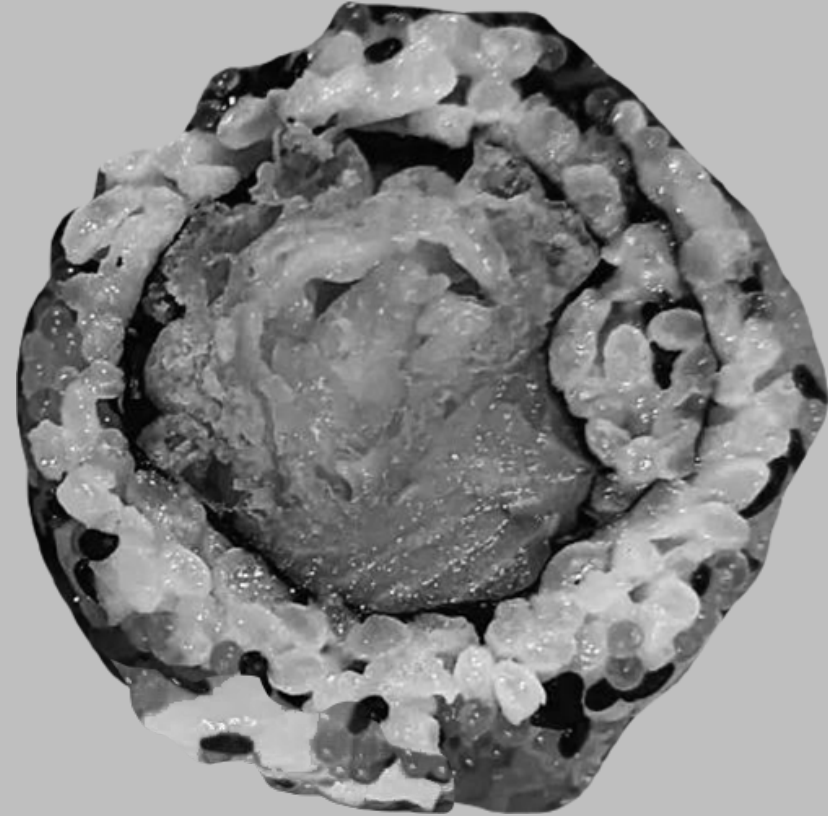

SUSHI MAKING TIPS



SUSHI RICE



SUSHI RICE IN AN INSTANTPOT (I DO NOT USE “RICE MODE”)

1. I LIKE TO START WITH SEKKA BRAND (LOOK FOR THE PINK BAG WITH BLOSSOMS)
2. TWO CUPS RICE INTO INSTANT POT VESSEL
3. WASH RICE, DRAINING REPEATEDLY UNTIL WATER IS CLEAR ENOUGH TO START SEEING THE RICE BELOW SURFACE
4. NOW YOU HAVE TWO CUPS OF DAMP RICE... SO POUR IN TWO CUPS OF WATER
5. SEAL LID AND LOW PRESSURE COOK FOR 14 MINUTES, WITHOUT “KEEP WARM” ENABLED
6. ALLOW PRESSURE TO RELEASE NATURALLY (THE PIN WILL FALL BACK DOWN EVENTUALLY)
7. ON THE SIDE, COMBINE 1/8 CUP RICE VINEGAR, 1/8 CUP MIRIN, 2 TSP SALT, 2 TSP SUGAR
(SOME PEOPLE OPT TO NUKE IT A SEC AND STIR THEM TOGETHER)
8. OPEN INSTANT POT, FLUFF RICE, ALLOW TO COOL FOR 5 OR 10 MINUTES IF YOU CAN
(REMOVE VESSEL FROM INSTANT POT HOUSING, GIVE IT A COOL PLACE TO STAND)
9. WITH RICE STILL SLIGHTLY WARM BUT NOT HOT, FOLD IN YOUR VINEGAR/MIRIN/SALT/SUGAR MIXTURE
(CHOP AND FOLD TECHNIQUE PREVENTS LARGER CLUMPS AND GLOOPY RICE)
(WOODEN PADDLE CAN HELP TO MANAGE MOISTURE)

SUSHI PREP



SUSHI PREP



SUSHI PREP



This is the same meme again.

SUSHI PREP



SUSHI PREP



AVOCA-WHOA VS. AVOCA-D'OH



AVOCA-WHOA VS. AVOCA-D'OH



AVOCA-WHOA VS. AVOCA-D'OH



CRUNCHY: BAD FOR PEANUT BUTTER, BUT GOOD FOR SUSHI ROLLS!



CRUNCHY: BAD FOR PEANUT BUTTER, BUT GOOD FOR SUSHI ROLLS!



CRUNCHY: BAD FOR PEANUT BUTTER, BUT GOOD FOR SUSHI ROLLS!



CRUNCHY: BAD FOR PEANUT BUTTER, BUT GOOD FOR SUSHI ROLLS!



CRUNCHY: BAD FOR PEANUT BUTTER, BUT GOOD FOR SUSHI ROLLS!



CRUNCHY: BAD FOR PEANUT BUTTER, BUT GOOD FOR SUSHI ROLLS!



CRUNCHY: BAD FOR PEANUT BUTTER, BUT GOOD FOR SUSHI ROLLS!



CRUNCHY: BAD FOR PEANUT BUTTER, BUT GOOD FOR SUSHI ROLLS!



CRUNCHY: BAD FOR PEANUT BUTTER, BUT GOOD FOR SUSHI ROLLS!



CRUNCHY: BAD FOR PEANUT BUTTER, BUT GOOD FOR SUSHI ROLLS!



CRUNCHY: BAD FOR PEANUT BUTTER, BUT GOOD FOR SUSHI ROLLS!



CRUNCHY: BAD FOR PEANUT BUTTER, BUT GOOD FOR SUSHI ROLLS!



CRUNCHY: BAD FOR PEANUT BUTTER, BUT GOOD FOR SUSHI ROLLS!



CRUNCHY: BAD FOR PEANUT BUTTER, BUT GOOD FOR SUSHI ROLLS!



CRUNCHY: BAD FOR PEANUT BUTTER, BUT GOOD FOR SUSHI ROLLS!



CRUNCHY: BAD FOR PEANUT BUTTER, BUT GOOD FOR SUSHI ROLLS!



CONTRASTING CREAMY AND CRUNCHY FTW



HAND ROLLS



THERE'S NOT ONE SINGULAR "PROPER" WAY

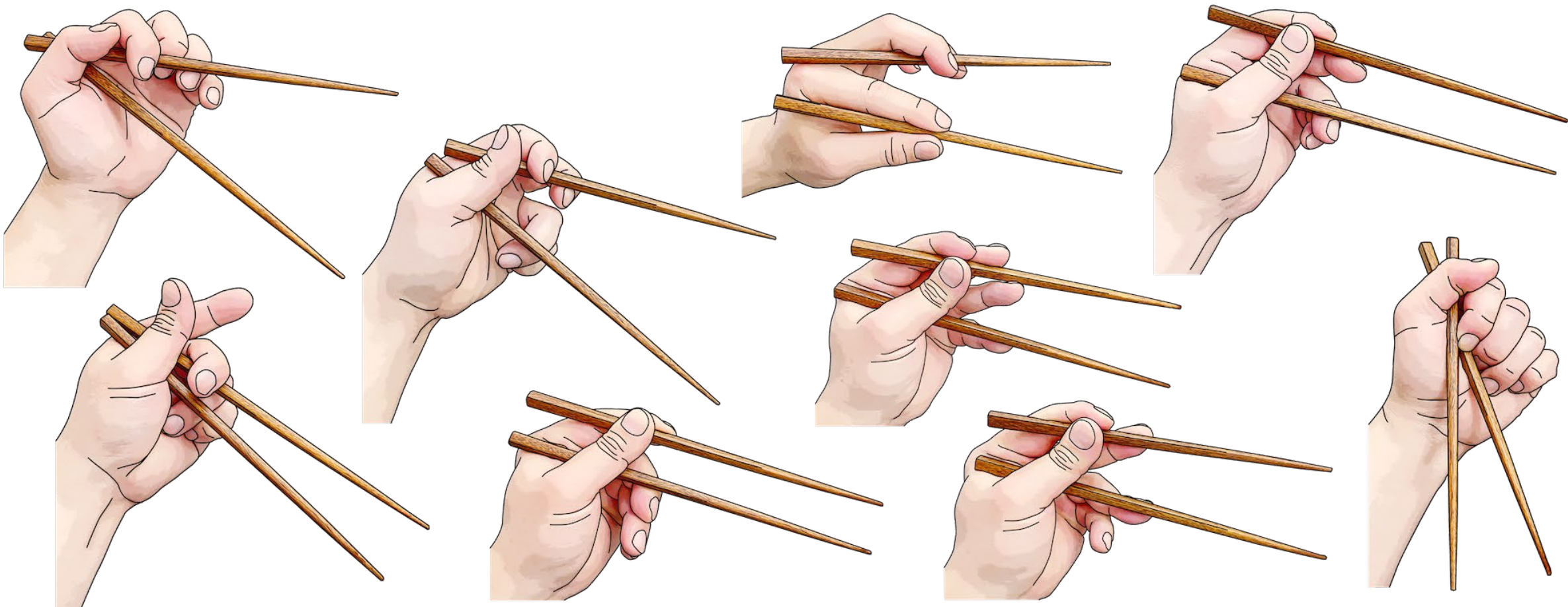

TRY NEW THINGS... RISKS ARE LOW, REWARDS ARE HIGH



TRY NEW THINGS... RISKS ARE LOW, REWARDS ARE HIGH

“You’re worth the time it takes to learn a new skill”

~ Mercury Stardust



STAY SAFE OUT THERE!



@DEVIANTOLLAM
@DEFCON.SOCIAL



/DEVIANTOLLAM



@DEVIANTOLLAM



/DEVIANTOLLAM

[HTTPS://DEVIATING.NET](https://deviating.net)